

Fulcrum Inc.



Instruction Manual:

AGC Precision Advanced Series

Models: AGC100 - AGC500, AGC1000 - AGC4000





Table of Contents

<u>Cautionary Notes and Precautions</u>	3
<u>1. Specification</u>	4
<u>2. Keys and Display Indicators</u>	6
<u>3. Commands and abbreviations</u>	7
<u>4. Parts Description</u>	8
<u>5. Unpacking the Scale and Getting Started</u>	9
<u>6. Weighing</u>	11
<u>6.1.1. Zeroing the scale</u>	11
<u>6.1.2. Taring</u>	12
<u>6.1.3. Clearing a Tare</u>	13
<u>7. Main Menu</u>	14
<u>7.1.1. Calibration</u>	14
<u>7.1.1.1. Start (Initializing Automatic Calibration)</u>	15
<u>7.1.1.2. Setup (Calibration Setup)</u>	16
<u>7.1.1.2.1. Calibration Adjustment</u>	17
<u>7.1.1.2.2. Time</u>	19
<u>7.1.1.2.3. Temperature</u>	21
<u>7.1.2. Units of Measure Selection</u>	22
<u>7.1.3. Mode configuration</u>	24
<u>(A) Animal Weighing</u>	25
<u>(B) Parts Counting</u>	28
<u>(C) Check Weighing</u>	29
<u>(D) Display Hold</u>	30
<u>(E) Percent Weighing</u>	32
<u>(F) Totalizing</u>	33
<u>7.1.4. Automatic Zero Setting Mechanism (AZSM)</u>	35
<u>7.1.5. GLP Print and Data Configuration</u>	37
<u>7.1.6. Printing Data and RS232 Communication Port Configurations</u>	40
<u>7.1.6.1. Baud and Parity</u>	40
<u>7.1.6.2. Torbal Printer Configuration (RXP-4)</u>	43
<u>7.1.6.3. Printout Receipts</u>	44
<u>7.1.7. Time and Date</u>	46
<u>7.1.8. Reset (restoring default factory settings)</u>	48
<u>8. Function Menu: Using the Modes and Functions</u>	50
<u>(A) Animal Weighing</u>	51
<u>(B) Parts Counting</u>	54
<u>(C) Check Weighing</u>	58
<u>(D) Display Hold</u>	61
<u>(E) Percent Weighing</u>	63
<u>(F) Totalizing</u>	66
<u>9. Technical Information</u>	69
<u>10. Common Errors and Troubleshooting</u>	70
<u>11. Maintenance</u>	71
<u>12. Accessories</u>	71
<u>13. Replacement Parts</u>	72
<u>14. Limited Warranty</u>	72



Important handling Cautions and Warnings

Always handle your scale with care.

Damage caused by improper handling is not covered under the scale's warranty.



Never drop or throw any articles onto the scale's pan or onto any other parts of the unit!



DO NOT let the scale fall or drop from its tabletop surface!

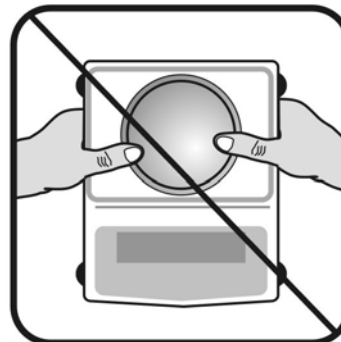

When moving the scale do not press or apply force onto the scales pan!



DO NOT pass or handle liquids directly over the scale to avoid spillage and liquid damage!

CAUTIONARY NOTES AND PRECAUTIONS

The TORBAL Precision scale is a sensitive and a delicate instrument. Always handle your scale with care.

The correct location and proper environment affect the accuracy of your TORBAL Precision Scale.

The best location for your scale:

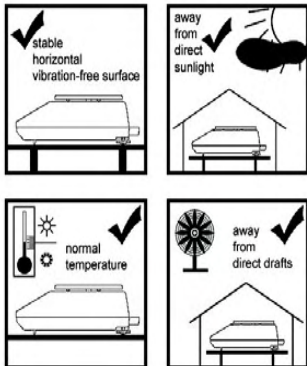

1. Stable, horizontal, vibration-free surface
2. Away from direct sunlight
3. Not exposed to high temperature variations
4. Away from direct drafts
5. The best location is on a stable bench away from drafts, doors, windows, radiators and air conditioner vents.

CAUTION:



- The scale is designed for indoor use only.
- Do not operate the scale in hazardous areas or under dangerous conditions.
- Do not use the scale in locations subject to high humidity or dust levels.
- Do not connect cables in ways other than those mentioned in this manual.
- Set the scale on a firm, stable, horizontal surface.
- Never stand on or lean on this product. Equipment may fall or collapse, causing breakage and possible injury.
- Before moving the product, unplug it and unplug all cables connected to it.
- When storing, transporting or returning the scale for service, use the original packaging.

WARNING:



- a. Never attempt to repair, disassemble or modify the scale. Tampering with the scale may result in injury and cause greater damage to the equipment.
- b. Never swap the pan, pan base, or any other parts of the scale with pans or parts from other units. Pans and all components are uniquely assigned to each unit.
- c. Be sure to use the specified power source.
- d. Do not allow foreign matter to fall into the scale.
- e. If water or other liquids spill into the scale, unplug the power cord immediately and contact technical support

TORBAL Precision scale is a sensitive and a delicate instrument. Always handle your scale with care.



CHAPTER 1. SPECIFICATION

	Model							
	AGC100	AGC200	AGC300	AGC500	AGC1000	AGC2000	AGC3000	AGC4000
Capacity	100g	200g	300g	500g	1000g	2000g	3000g	4000g
Readability (d)	0.001				0.01			
Repeatability (Standard Deviation)	0.001g				0.01g			
Linearity	+/- 0.002g				+/- 0.02g			
Stabilization time (typical)	Approx. 3 sec				Approx. 3 sec			
Tare Range	-100g	-200g	-300g	-500g	-1000g	-2000g	-3000g	-4000g
Accuracy Class	II							
Automatic Internal Calibration	YES							
Time Configuration	1h, 2h, 3h, 4h, 5h, 6h							
Temperature Configuration	0.5°C, 1.0°C, 1.5°C, 2.0°C							
Automatic Calibration Adjustment Masses (g)	20,50, 100	50, 100, 200	100, 200, 300	100, 200, 500	200, 500, 1000	500, 1000, 2000	1000, 2000, 3000	1000, 2000, 4000
Pan Dimension	120mm				165mm x 165mm			
Draft Shield	Optional				Not Required			
Scale Dimension	216 x 345 x 90 mm							
Operating Temperature	+15°C to +30°C							
RS232 Port	Bidirectional							
Power Supply	Input: 120VAC 60Hz 15W Output: 12VDC 500mA							
Display Type	Seven Segment LCD							
Display Size	30mm x 100mm							
Application Modes	Weighing , Parts Counting , Animal Weighing , Check Weighing , Display Hold , Percent Weighing , Totalizing							
GLP	YES							
Weighing Units	Grams, Kilograms, Carats, Pounds, Newton, Grains, Ounces, Ounces Troy, Pennyweight							
Scale's Net Weight (lb/kg)	5kg / 11lbs							
Parts Counting	Sample Size	1 through 100						
	Min Piece Weigh	30mg			300mg			
Percent Weighing	Min Reference Weight	100mg			1g			
	% Resolution Displayed (Reference Weight)	0.1% (100mg to 7g), 0.01% (7g to 70g) 0.001% (> 70g)			0.1% (1g to 70g), 0.01% (70g to 700g) 0.001% (> 700g)			
Animal Weighing	Tine Intervals	3sec., 5sec., 10sec., 15sec.						
	Modes (Min Weight)	Manual, Auto (10mg), Semi-Auto (10mg)			Manual, Auto (100mg), Semi-Auto (100mg)			
Totalizing	Modes (Min Weight)	Manual, Auto (10mg), Semi-Auto (10mg)			Manual, Auto (100mg), Semi-Auto (100mg)			
Display Hold	Modes (Min Weight)	Manual, Auto (10mg), Semi-Auto (10mg)			Manual, Auto (100mg), Semi-Auto (100mg)			



KEYS AND DISPLAY INDICATORS

Key	Primary Function	Secondary Function
	Power On and Power Off	-
T (YES)	Tare – used to tare the weighing pan	Enter and YES (Accept) – used to enter or accept commands
→0← (NO)	Zero – used to zero the scale	NO (Reject) – used to reject commands or change values
Menu	Menu – used to access the main menu	Recall – in Totalizing this key is used to recall the Grand Total
Function	Function – used to select an application mode	Add / Start / Lock – In Totalizing (Manual) this key is used to add a result to the total. In Animal Weighing (Manual) this key is used to initiate the animal weighing process. In Display Hold (Manual) this key is used to lock the weighing result on the display.
P	Print – used to initiate printing	Decimal – used to enter a decimal when assigning limit values in check-weighing
C	Clear / Cancel – used to clear or cancel a function	Exit- used to exit submenus
Display Indicator	Description	Explanation
OFF	Power Off	The scale is turned OFF and in standby mode.
AUT	AZSM (Automatic Zero Setting Mechanism)	AZSM (Automatic Zero Setting Mechanism) is active and the scale maintains a “center of zero” condition within +/- 6d.
NET	Net Result	A tare was taken and the scale subtracted the tare weight from the gross weight to obtain the net weight.
→0←	Zero	The scale is maintaining a “center of zero” condition.
O	Current setting	Indicates enabled functions or settings
MODE	Main Menu	Indicates Main Menu functions
	Stability Indicator	The weighing result has stabilized and an accurate reading may be taken.
MIN	Minimum	In check weighing <i>MIN</i> indicates the weighing result is below the selected under limit.
MAX	Maximum	In check weighing <i>MAX</i> indicates that the weighing result is above the over limit.
OK	Accept	In check weighing <i>OK</i> indicates that the weighing result is between the selected limits and the result is acceptable.
TOTAL	Total Result	In totalizing this indicator signals that the displayed result is a total sum.
pcs	Pieces	In parts count this indicator shows that the result is a piece count.
%	Percent	In percent weighing this indicator shows that the result is a percentage.



CHAPTER 3.

COMMANDS AND ABBREVIATIONS

Command or Abbreviation	Description
-----	Taring or re-zeroing in progress
CAL	The scale is in the calibration mode.
TARING	The scale is taring before the calibration process.
LOAD XXX g	Place a calibration weight on the pan to begin calibration.
C	Calibration in progress
CAL FIN	Calibration procedure is finished.
AW – X	In animal weight this command represents the average weighing time.
CONT	In parts counting, taring a container is required before continuing the counting transaction.
SAPL ON	In parts counting or percent weighing this command indicates to place the sample on the pan.
SPL – XX	In parts counting this command represents the current sample size setting.
FILL	In parts counting, begin counting.
UNDER	In check weighing this command represents the under limit and indicates under result.
OVER	In check weighing this command represents the over limit and indicates an over result.
ACCEPT	In check weighing this command indicates that the weighing result is within the limit range.
TARE	In check weighing, tare before continuing.
SAMPLE	In percent weighing this command indicates the weight of a stored reference weight.
READY	In percent weighing this command indicates that the scale is ready for percent weighing based on a stored reference weight.
YES-NO	In totalizing this command indicates that a confirmation is required before the Totals are cleared.
PRINT	Printing in progress
COUNT FINISH TO START COUNT PRESS C	In parts counting this command indicates that parts counting is finished.

CHAPTER 4. PARTS DESCRIPTION



Front View

Rear View



Pan

Pan Base

AC Adapter

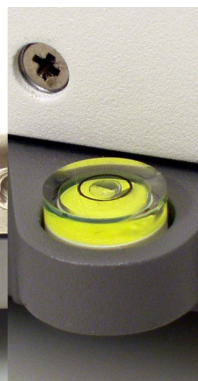
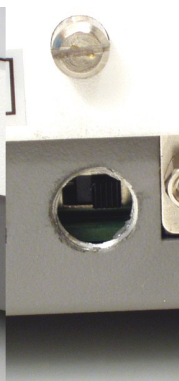

RS232 Serial Port

Service Switch

Level Indicator

AC Adapter Socket

CHAPTER 5.**UNPACKING THE SCALE AND GETTING STARTED**

1. Carefully remove the scale, pan, and all of its components from packaging. Place them on a stable base where the scale will not be affected by any mechanical vibrations or air movements.



2. After removing the pan base and the pan from their packaging, carefully install the pan base onto the scale by seating it on the pan support located in the middle of the scale. Once the pan base has been installed, carefully place the pan on the base as shown below.

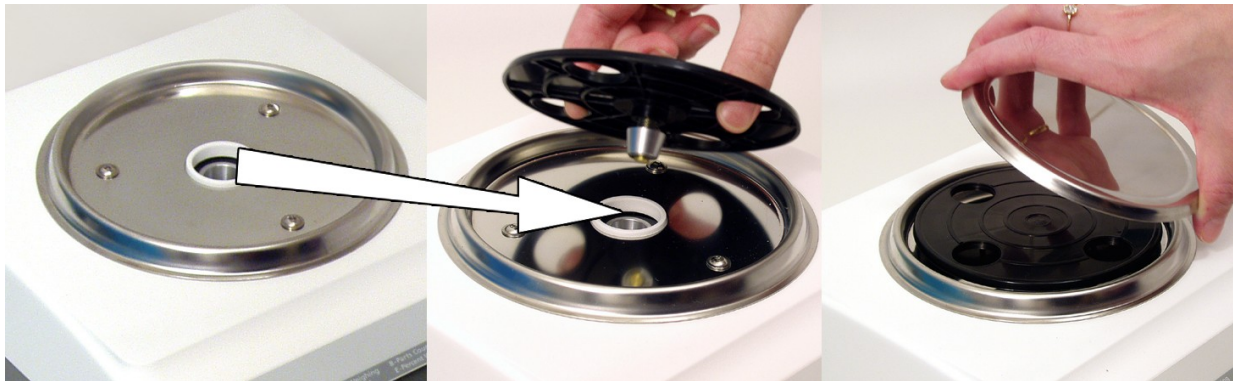

- Once the pan has been installed, level the scale by adjusting the rear feet until the level indicator shows the “air bubble” is in the center position of the sight glass. The level indicator is located on the rear left side of the scale.

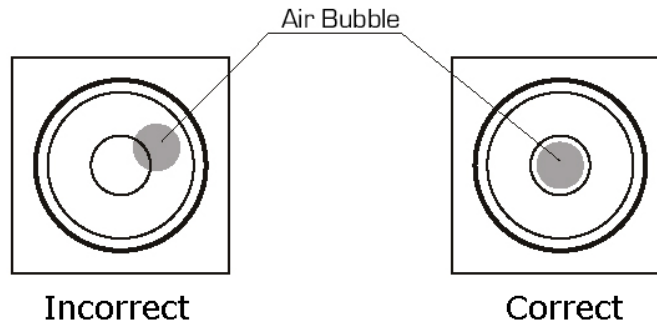

- After leveling the scale, plug the AC adapter into the AC adapter socket on the rear of the scale.



- When the AC adapter is plugged into the wall outlet, the scale will turn “ON” automatically, initialize itself, perform automatic internal calibration and enter weighing mode.
- To put the scale into standby mode, leave the AC adapter plugged into both the scale and the wall outlet and press the power “OFF” button (ϕ). *OFF* will light up on the upper left corner of the display, signaling the scale is in standby mode.

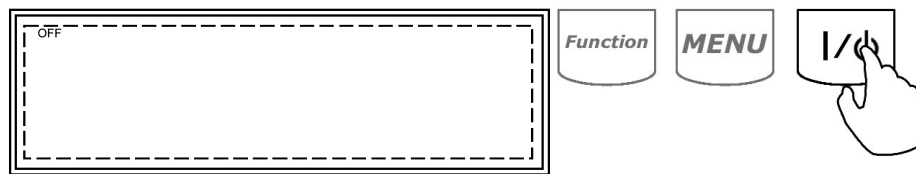

CHAPTER 6. WEIGHING

1. To begin weighing, press the power button (ϕ) to turn the scale on. The scale will initialize, perform automatic internal calibration and enter the weighing mode. The scale is ready to begin weighing as soon as the stabilization (\blacktriangledown) and center of zero ($\rightarrow 0 \leftarrow$) indicators appear on the display



2. When weighing, always place the mass in the middle of the pan. The weighed result may be taken when the stabilization indicator appears on the display.

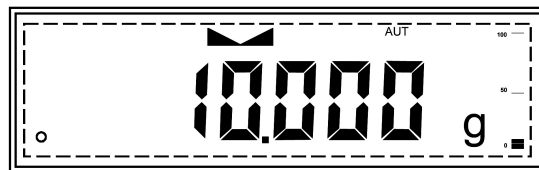

6.1.1. Zeroing the scale

1. The scale may be re-zeroed manually to obtain a new “center of zero.” To re-zero the scale manually, make sure the weight and the stabilization indicator are shown on the display.
2. Re-zero the scale by pressing the zero key $\rightarrow 0 \leftarrow$.

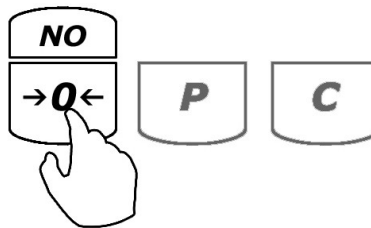

3. The display will show a dotted line, which indicates the scale is re-zeroing.

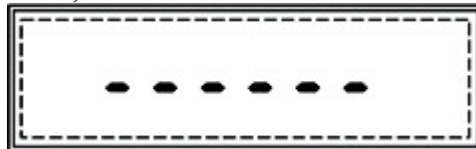

- When it has finished re-zeroing, the scale will return to weighing mode and the display will indicate *0.000g*. A new center of zero has been set, and the scale is ready for use.

6.1.2. Taring

- If a container is used for weighing, it may be tared. Taring subtracts the weight of the container from the gross weight to obtain the net weight.
- To tare the weighing container, place it in the middle of the pan. The container's weight will be shown on the display.

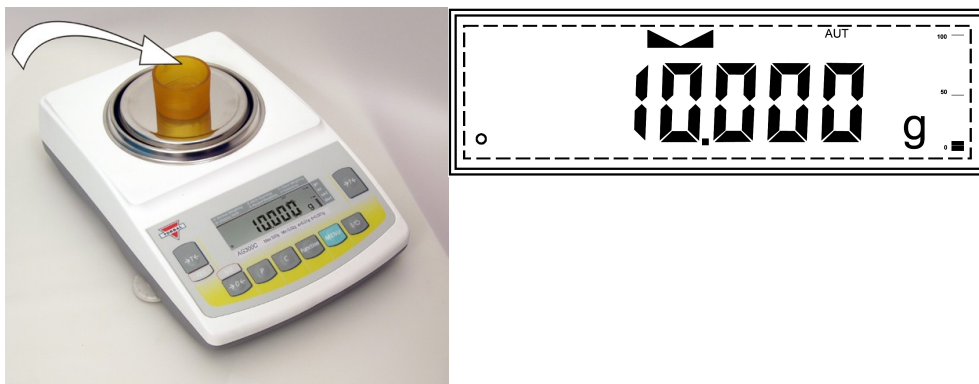

- Once the stabilization indicator appears on the display, the container is ready to be tared. To tare the container, press the “T” button. The display will show a dotted line, indicating that the scale has begun the taring process,

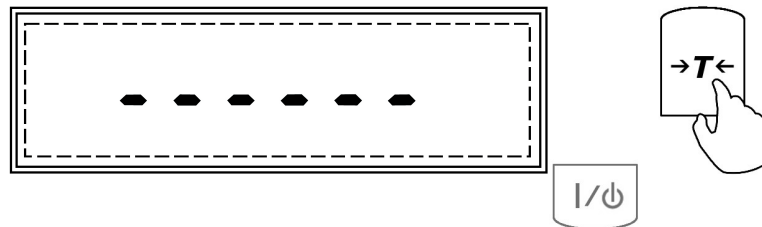

- When finished taring, the balance will return to weighing mode. The display will indicate *0.000g*, and *NET* indicator will be shown on the display signaling the next weight taken is a net result.

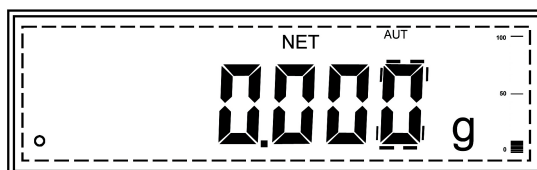

6.1.3. Clearing a Tare

1. To clear the tare, remove the tared object along with the net weight from the pan. The scale will then display a negative net tare result.

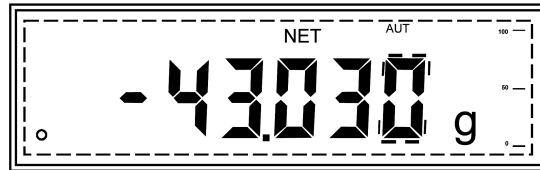

2. To clear the tare, press the "T" button.

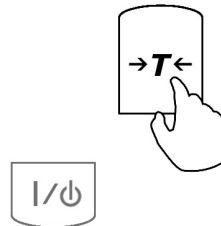

3. The display will show dashed lines indicating the tare is clearing.

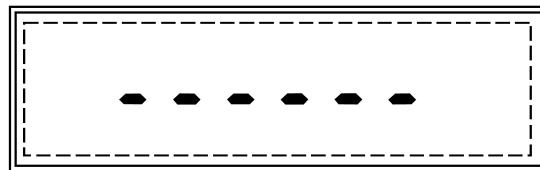

4. When it has finished clearing the tare, the scale will return to weighing mode.

CHAPTER 7. MAIN MENU

Main Menu is used to configure the scale and its weighing modes. Before entering the menu, complete and clear any active function by pressing the “C” key. To enter the Main Menu press the “MENU” key. Once the “MENU” key is pressed the scale will display available Menu options. Commands: *CALIB*, *UNIT*, *MODE*, *AUTO*, *GLP*, *PRINT*, *SET TD* and *RESET* will flash sequentially. To select and enter a desired menu option press the “T” (YES) key while that menu option is displayed.

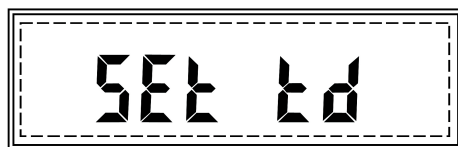
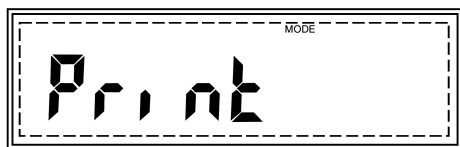
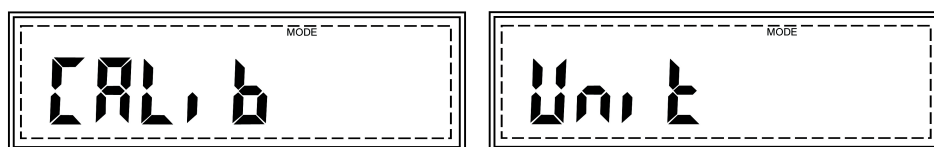

Note: Scrolling through the options may be accelerated by manually pressing the →0← (NO) key.

7.1.1. Calibration

When the scale is initially installed, it will automatically calibrate at startup to ensure accuracy of weighing results. Calibration should be performed periodically or whenever the scale is moved. You can also configure the scale to calibrate automatically with time and temperature variations. To calibrate the scale and configure automatic calibration settings follow the steps below.

7.1.1.1.Start (Initializing Automatic Calibration)

To calibrate the scale, follow the steps below:

1. Press “MENU” to enter the Main Menu.

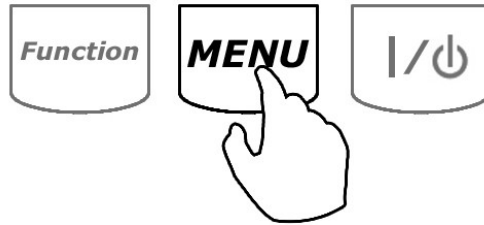

2. When *CALIB* is displayed, press “T” (YES).

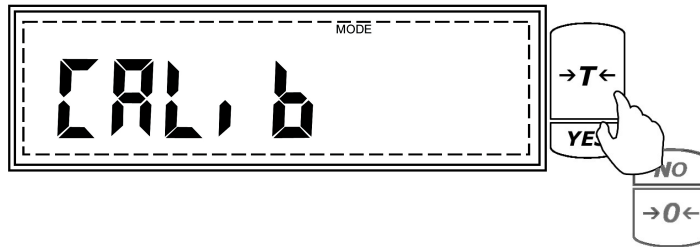

3. The scale will display commands *Start* and *Setup* sequentially. Press , “T” , when *Start* is displayed.



4. The scale will display *CAL*, indicating that the calibration mode has been entered.

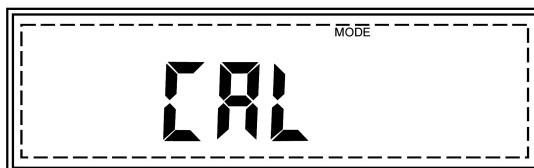

5. Before calibration begins, the scale will perform automatic tare. *TARING* will be displayed during auto tare.

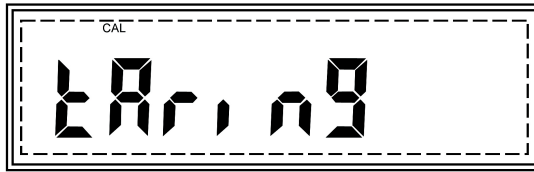

6. Once the scale tares, command "*LOAD C*" will be displayed, followed by "C" indicating that automatic calibration is in progress.

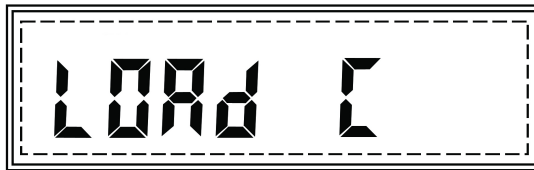

7. Calibration can last from 30 to 50 seconds, when it is finished the scale will automatically return to the weighing mode.

7.1.1.2. Setup (Calibration Setup)

To enter the automatic calibration setup menu, follow the steps below:

1. Press "Menu" to enter the Main Menu

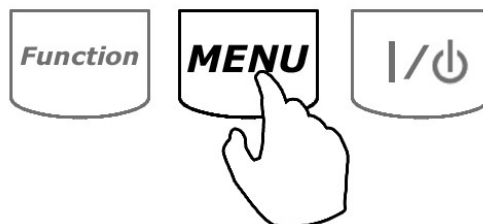

- When *CALIB* is displayed, press “T” (YES).

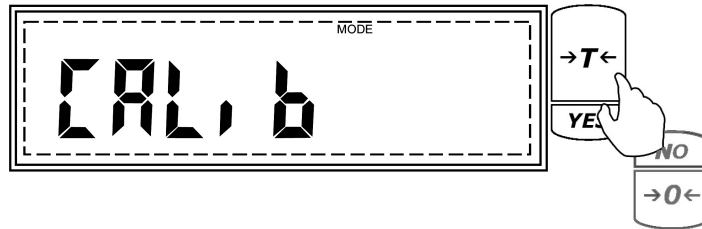

- The scale will display commands *Start* and *Setup* sequentially. Press , “T” , when Setup is displayed.



- Commands *CALIB* (Calibration Adjustment), *TIME* (Time Configuration), and *TEMP* (Temperature Configuration) will begin to scroll sequentially.

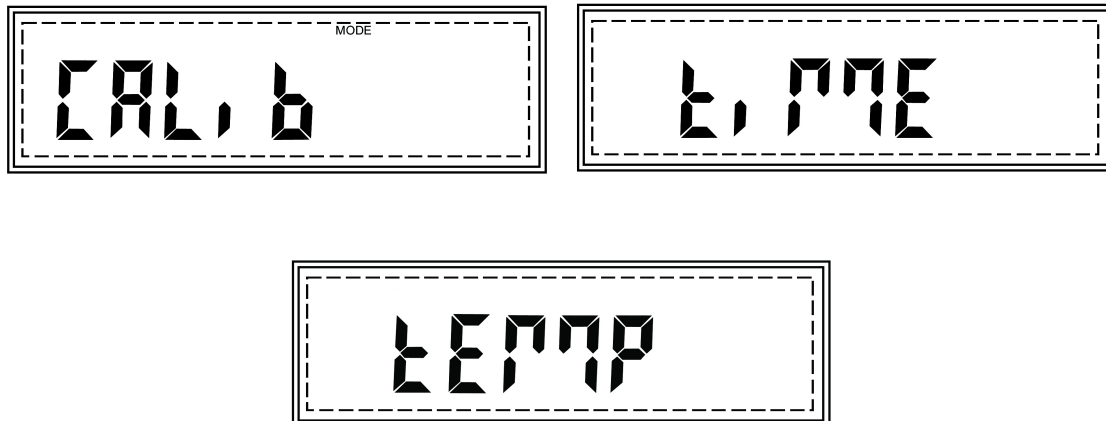

7.1.1.2.1. Calibration Adjustment

The Calibration Adjustment function allows the internal calibration mass value to be adjusted with an external calibration weight that has a traceable class certification. To perform calibration adjustments follow the steps below:

1. Press the “T” (YES) key when “CALIB” is displayed in the calibration setup menu.

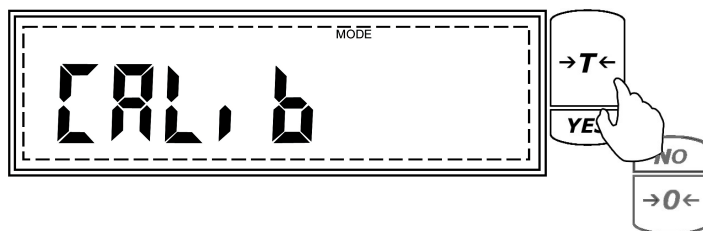

2. The scale will display *CAL*, indicating that the calibration adjustment mode has been entered.

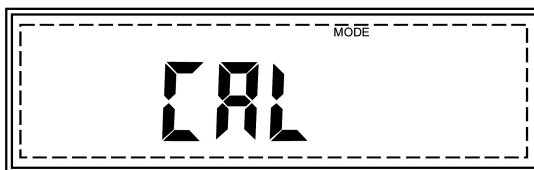

3. Before calibration adjustment can begin, the scale will perform automatic tare. *TARING* will be displayed during auto tare.

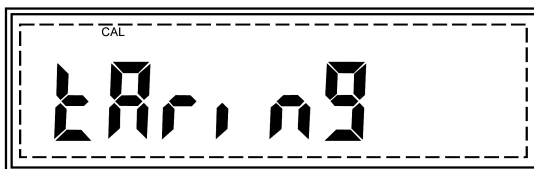

4. Once the scale has been tared the current calibration mass setting will be displayed. To change the calibration mass, press the →0← (NO) key. After making the selection press the “T” (Yes) key to accept and confirm the setting.

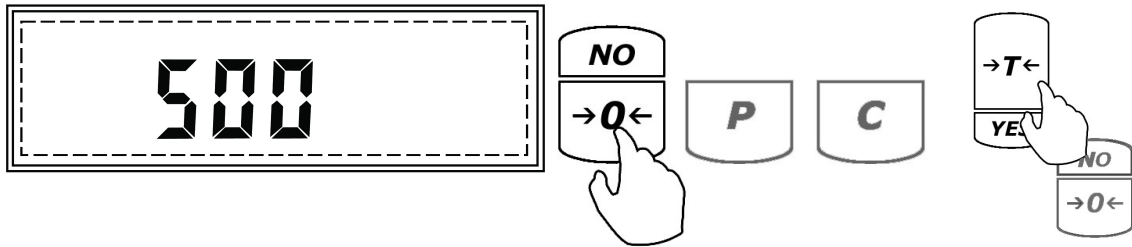

To Change

To Accept

- Command *LOAD* will be displayed. At any time during the *LOAD* command, place a single calibration weight in the middle of the pan.



- Command “C” will be displayed indicating that the scale is recording a new calibration mass value.

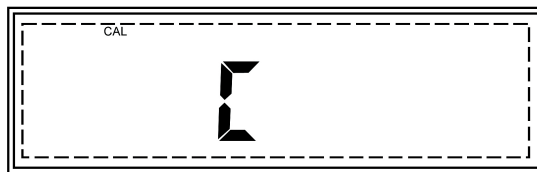

- Once the new calibration value is stored the command “*UNLOAD*” will be displayed indicating to remove the calibration weight from the pan.



- Once the weight is removed the scale will continue with calibration adjustment. *CAL* will be displayed during the remainder of the adjustment process. Once finished the scale will automatically return to the weighing mode.

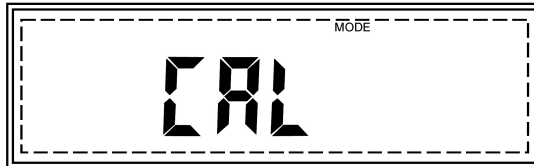

7.1.1.2.2. Time

Internal calibration can be configured to calibrate automatically within a change of time. To set a calibration time interval, follow the steps below.

- Press the “T” (YES) key when “*TIME*” is displayed in the calibration setup menu.

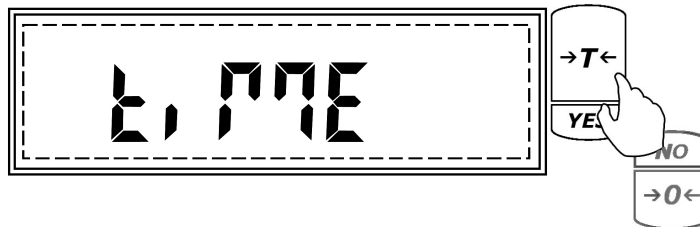

- “t-0” and the current time interval setting will begin to scroll on the display sequentially. To disable time interval calibration press the “T” (YES) key when “t-0” is displayed. To enable time calibration press the “T” (YES) key when the default time setting is displayed.

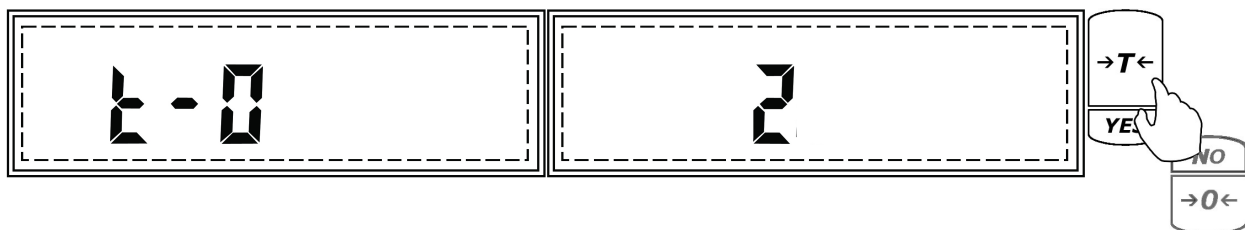

To Disable

To Enable

3. A dash will appear on the display indicating to enter a desired time interval. The time interval can be set between 1, 2, 3, 4, 5, and 6 hours (i.e. if set to 3, calibration will be performed once every 3 hours).

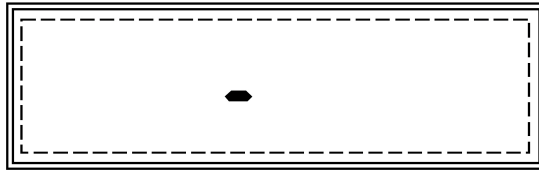

4. To set a calibration time interval press the $\rightarrow 0 \leftarrow$ (NO) key until the desired setting is displayed.

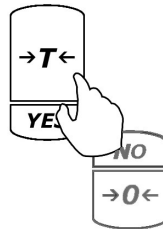

5. When the desired setting is displayed press the “Function” key to accept and save the selection. The scale will return to the Calibration Menu. To exit the Menu, press the C key.

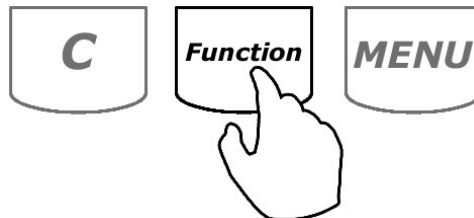

7.1.1.2.3. Temperature

Internal calibration can be configured to calibrate automatically within a change of temperature. To set a calibration temperature interval, follow the steps below

1. Press the “T” (YES) key when “TEMP” is displayed in the calibration setup menu.

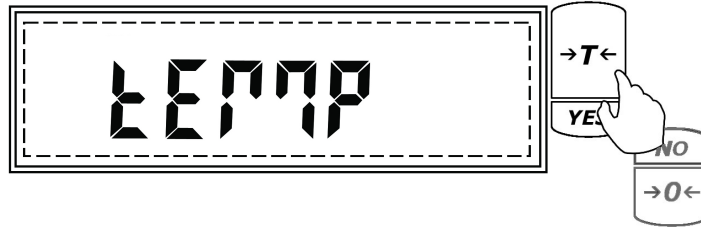

2. “°C - 0” and the current temperature interval setting will begin to scroll on the display sequentially. To disable temperature interval calibration press the “T” (YES) key when “°C - 0” is displayed. To enable temperature calibration press the “T” (YES) key when the temperature setting is displayed.

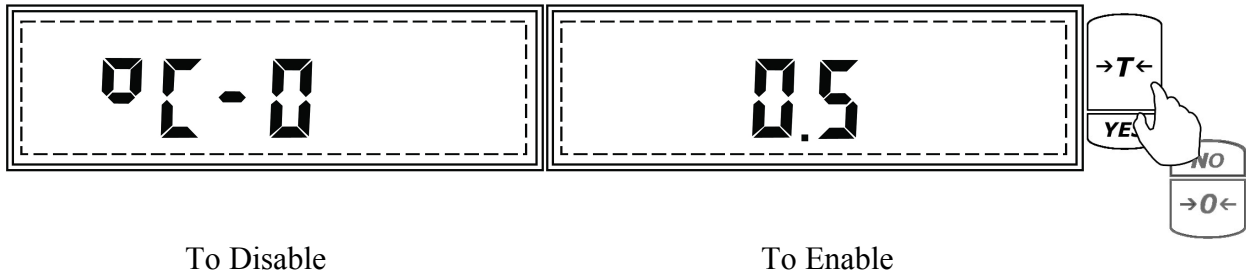

3. The temperature interval can be set to 0.5°C, 1.0 °C, 1.5 °C, 2.0 °C (i.e. if set to 2.0 °C, calibration will be performed every time the temperature changes by 2.0 °C).
4. To set a calibration temperature interval press the →0← (NO) key until the desired setting is displayed.

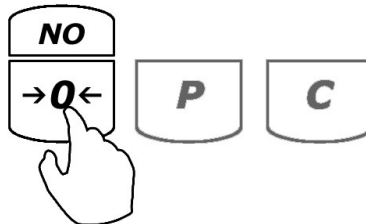



- When the desired setting is displayed press the “Function” key to accept and save the selection. The scale will return to the Calibration Menu. To exit the Menu, press the C key.

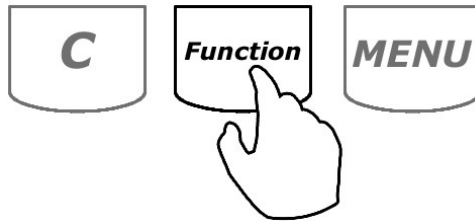

7.1.2. Units of Measure Selection

TORBAL AGC series scales can operate in nine different units of measure: grams (g), kilograms (kg), carats (ct), pounds (lb), Newton (n), grains (gn), ounces (oz), ounces troy (oz-t), and pennyweights (dwt).

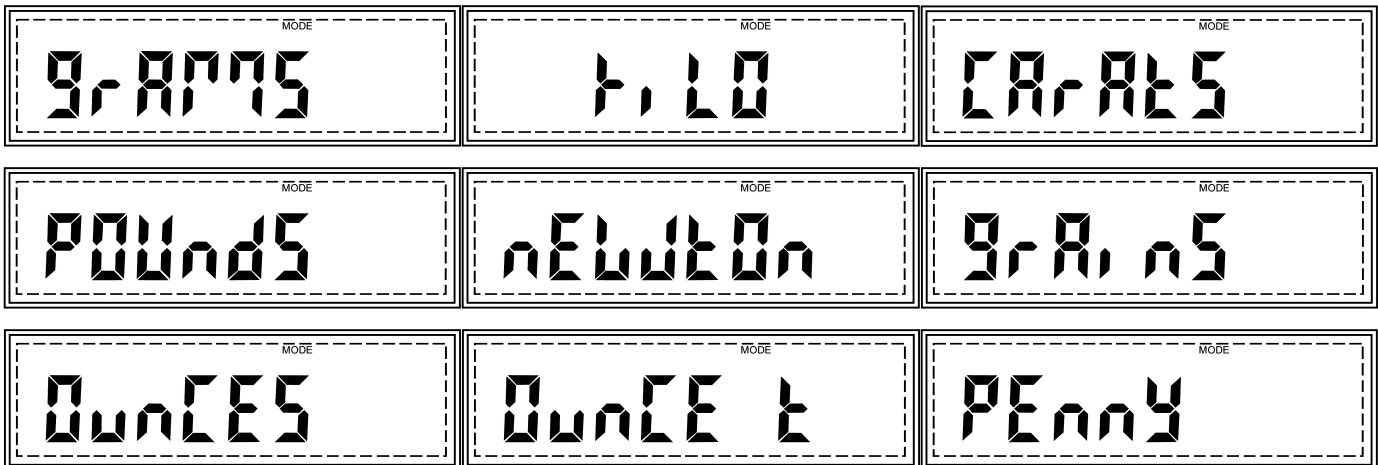

By factory default the scale is set to weigh in grams (g). To select a different unit, follow the steps below.

- Enter the Main Menu by pressing the “MENU” key.

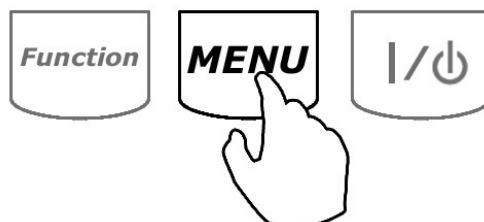

- When command *UNIT* is displayed press the “T” (Yes) key.

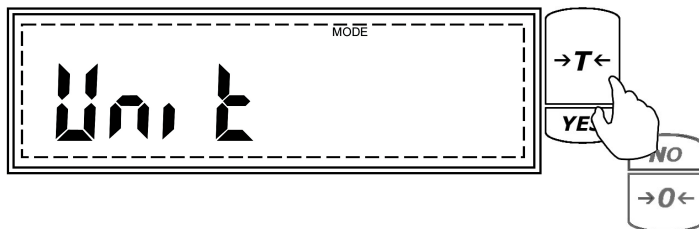

- The scale will display available units of measure sequentially. When the desired unit is displayed, press the “T” (Yes) key to make the selection.

Example (Selecting Ounces)



- To exit the Main Menu, use the “C” key.

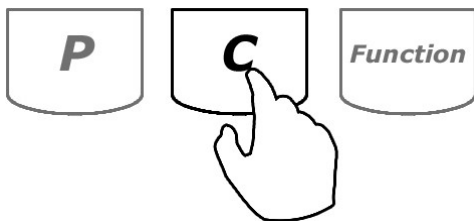



Important:

- The symbols for grams (g), kilograms (kg), carats (ct), pounds (lb), and Newton (n) will appear to the right of the measurement on the LCD display.

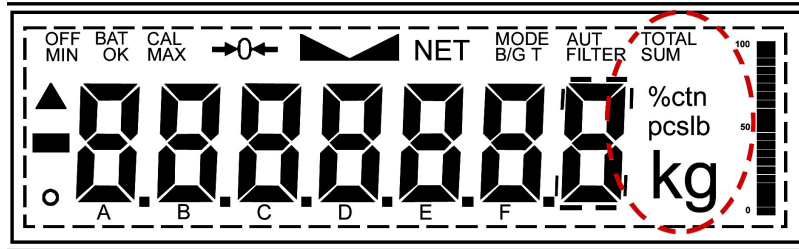

- The symbols for grains (gn), ounces (oz), ounces troy (oz-t), and pennyweight (dwt) are printed on the scale’s panel and an equal sign will point to the symbol indicating the current unit.

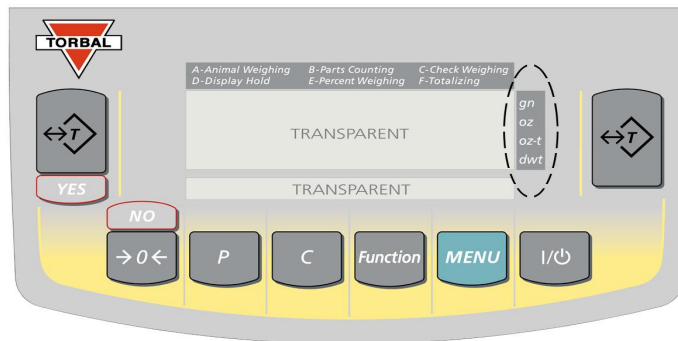

7.1.3.Mode configuration

TORBAL AGC series scales can operate in seven application modes. A- Animal Weighing, B – Parts Counting, C - Check Weighing, D – Display Hold, E-Percent Weighing, and F-Totalizing. Before an application mode can be used, it must be enabled and configured. Once the application mode is enabled it will be available for selection from the Function Menu.

By factory default the scale is in the weighing mode (*WEIGH*). To enable other application modes, follow the steps below.

1. Enter the Main Menu by pressing the “MENU” key.

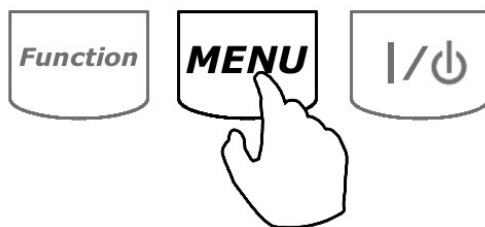

2. When *MODE* is displayed press the “T” (YES) key.

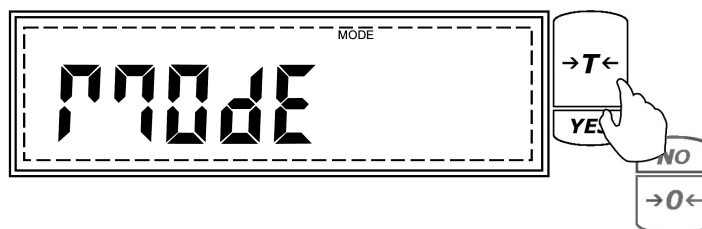

3. The application modes will now begin to display sequentially. Press the “T” key when the desired application is displayed and follow the configuration steps for that mode.

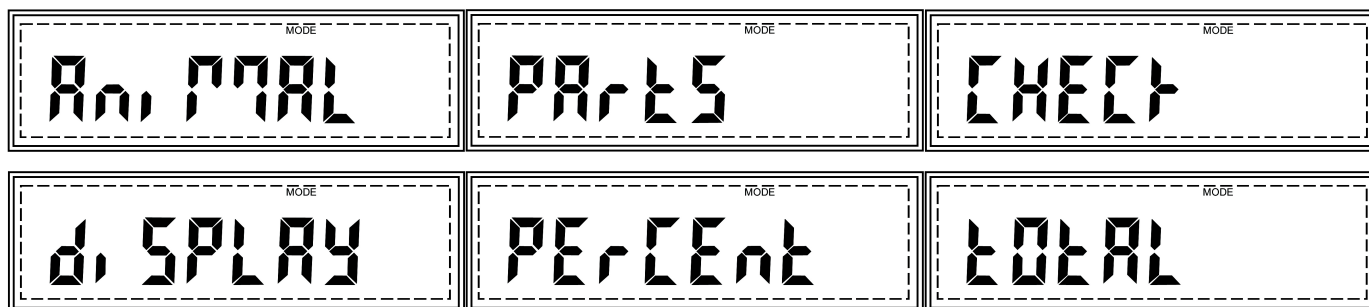

Note: Scrolling through the options may be accelerated by pressing the →0← (NO) key.

(A) Animal Weighing

1. To enable animal weighing, press the “T” (YES) key when *ANIMAL* is displayed.

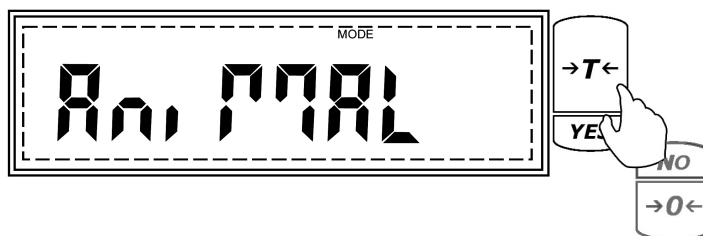



- Commands *An On* and *An OFF* will be displayed sequentially. To enable animal weighing and proceed with configuration press the “T” (YES) key when *An On* is displayed. If the function is already enabled and you wish to disable it, press the “T” (Yes) key when *An OFF* is displayed.

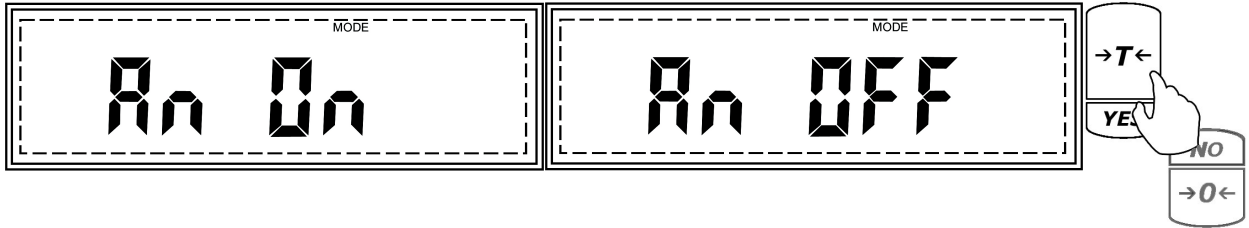

- Animal weighing can operate in three different modes: automatic, semi-automatic and manual (see Table 7.1.3.A). The operating modes will begin to scroll once the function is enabled. To select a desired operating mode for animal weighing, press the “T” (YES) key while the mode is displayed. To enable automatic animal weighing, press “T” (YES) while AUTO is displayed.

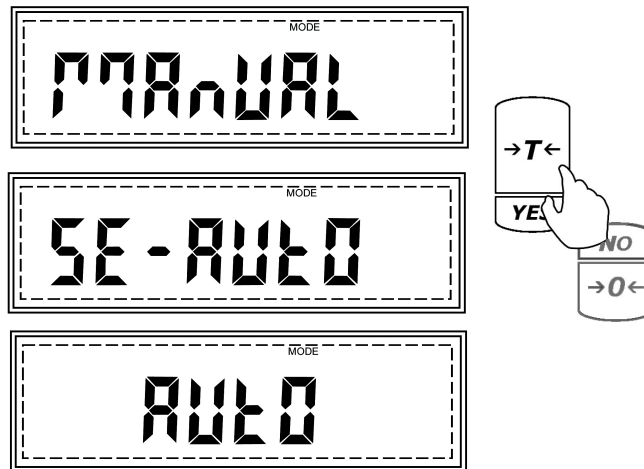

4. Once the desired operating mode for animal weighing has been selected, the scale will display time intervals for the animal weighing process. The intervals t-3 (3 seconds), t-5 (5 seconds), t-10 (10 seconds), and t-15 (15 seconds) will display sequentially. To select a time interval, press the “T” (YES) key when the desired time interval is displayed.

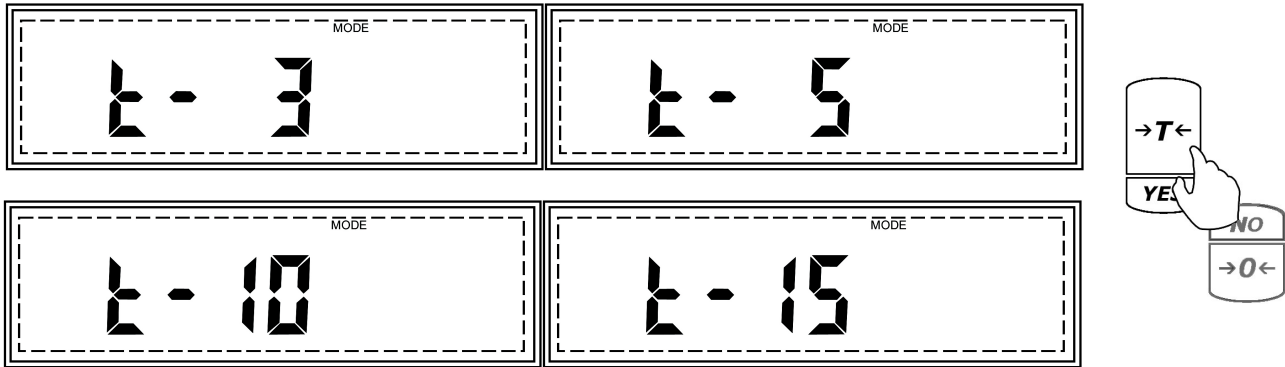

Note: Select longer time intervals when weighing very active animals. Longer time intervals will allow the scale to take more readings while the animal is moving on the pan and provide an accurate result.

5. After selecting the time interval, *DONE* will be displayed, indicating that the function has been configured and it is ready to use. To use the function, follow the directions given in Chapter 8. To exit the mode menu use the “C” key.

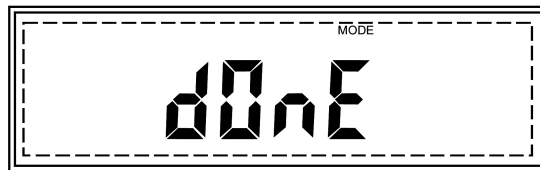

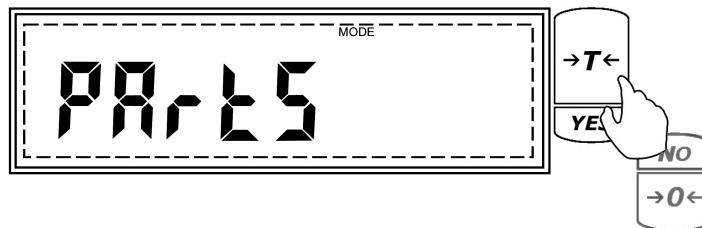

Table 7.1.3.A: Animal Weighing Operating Modes

Automatic	Weighing Initialization: Automatic Result Clearing: Automatic Tare: Automatic	When set to Automatic, the scale will automatically begin the animal weighing process. Once the animal is removed from the weighing pan, the scale will automatically tare and prepare for the next weighing.
Semi-Automatic	Weighing Initialization: Automatic Result Clearing: Manual Tare: Manual	When set to Semi-Automatic, the scale will automatically begin the animal weighing process. Once the animal is removed from the weighing pan the result remains displayed until it is manually cleared. The scale must be manually tared before the next weighing.
Manual	Weighing Initialization: Manual Result Clearing: Manual Tare: Manual	When set to Manual, the animal weighing process must be manually initialized. Once the animal has been weighed and the pan cleared the result must be manually cleared. The scale must be manually tared before the next weighing.

(B) Parts Counting

1. To enable parts counting press the “T” (YES) key when *Parts* is displayed.



2. Commands *Co On* and *Co OFF* will be displayed sequentially. To enable parts counting and proceed with configuration press the “T” (YES) key when *Co On* is displayed. If the function is already enabled and you wish to disable it, press the “T” (Yes) key when *Co OFF* is displayed.

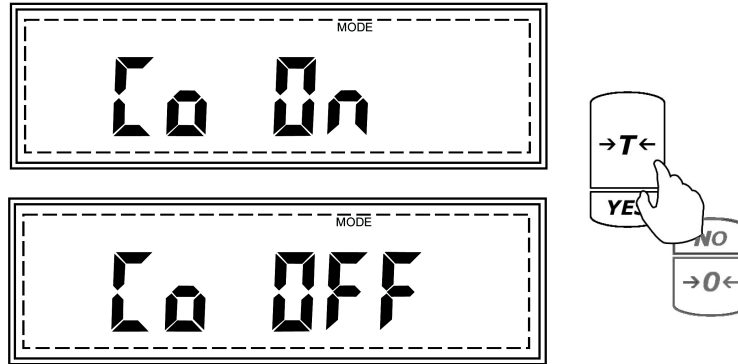

3. After enabling parts counting, select the sample size you want to be used for establishing the average piece weight (APW). SPL – 10 will be displayed indicating that the default sample size setting is 10 pieces. To accept the sample size press the “T” (YES) key. To change the sample size press the →0← (NO) key.

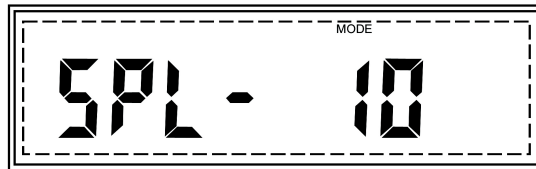

To Accept

To Change

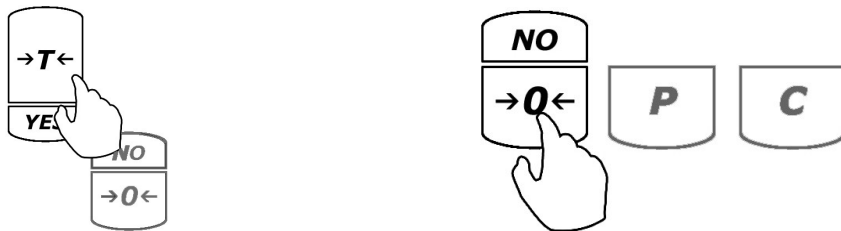

The sample size selection can range from 1 to 100 pieces. By applying short single presses to the →0← (NO) key the sample size will change in increments of one. By holding the →0← (NO) key pressed, the sample size will change in increments of 5. To select a sample size of 99, press and hold the →0← key until the display reads 95, and apply four single presses until the sample size reads 99. Once a desired sample size is displayed, press the “T” (YES) key to accept and confirm the selection.

Note: Larger sample size results in a more accurate average piece weight. Select a sample size greater than 10 pieces if a large weight variance might exist between the counted pieces.

- After selecting the sample size, *DONE* will be displayed indicating that the function has been configured and it is ready to use. To use the function follow the directions in Chapter 8. To exit the mode menu use the “C” key.

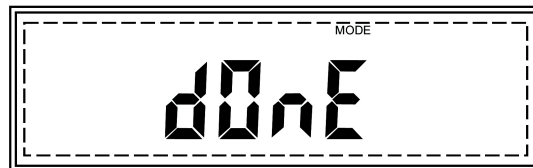

(C) Check Weighing

- To enable check weighing press the “T” (YES) key when *Check* is displayed.

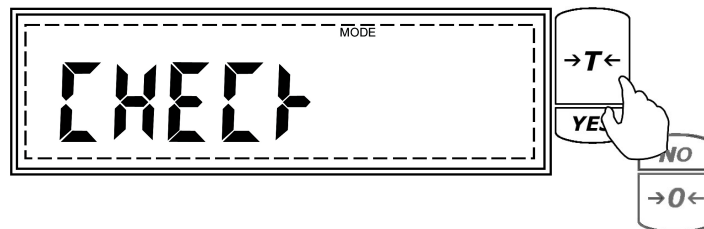

- Commands *CHK On* and *CHK OFF* will be displayed sequentially. To enable check weighing press the “T” (YES) key when *CHK On* is displayed. If the function is already enabled and you wish to disable it, press the “T” (Yes) key when *CHK OFF* is displayed.

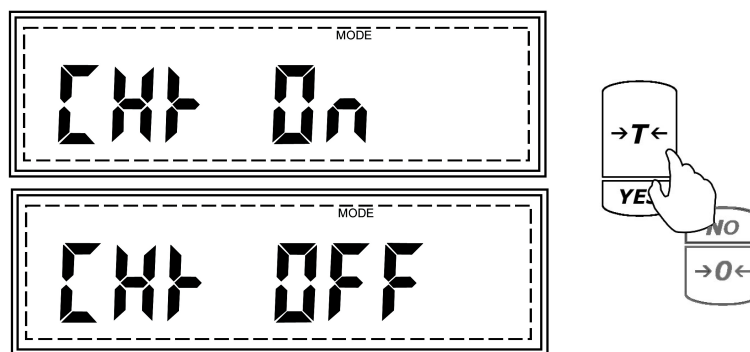

- After enabling check weighing, *DONE* will be displayed indicating that the function has been configured and that the scale is ready for use. To use the function, follow the directions in Chapter 8. To exit the mode menu use the “C” key.

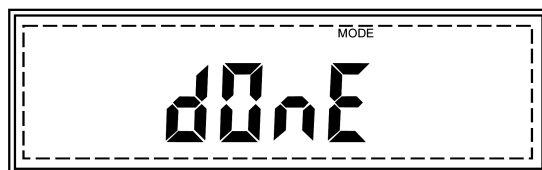

(D) Display Hold

- To enable display hold press the “T” (YES) key when *Display* is displayed.

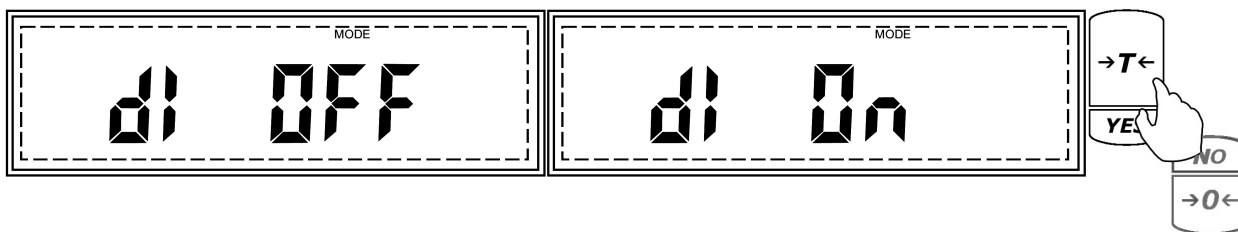

- Commands *Di On* and *Di OFF* will be displayed sequentially. To enable display hold and proceed with configuration press the “T” (YES) key when *Di On* is displayed. If the function is already enabled and you wish to disable it, press the “T” (Yes) key when *Di OFF* is displayed.



3. Display hold can operate in three different operating modes: automatic, semi-automatic and manual (see table 7.1.3.D). The operating modes will scroll once the function is enabled. To select a desired operating mode for display hold, press the “T” (YES) key while the mode is displayed. To enable automatic display hold press “T” (YES) while *AUTO* is displayed.

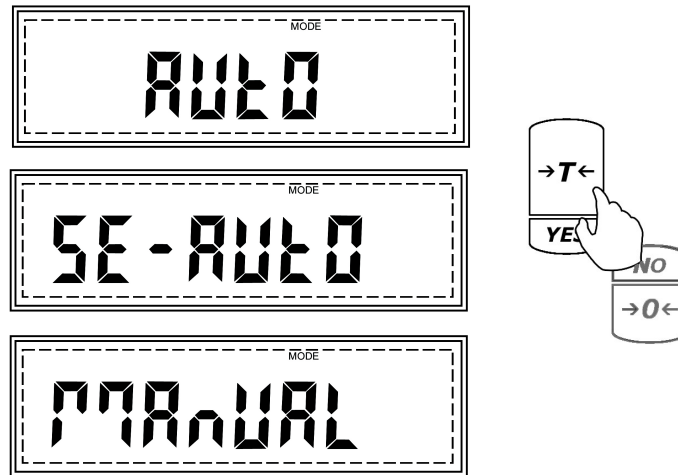

4. After enabling the display hold function, *DONE* will be displayed, indicating that the function has been configured and it is ready to use. To use the function follow the directions in Chapter 8. To exit the mode menu,, use the “C” key



Table 7.1.3.D: Display Hold Operating Modes

Automatic	Display Hold initialization: Automatic Result Clearing: Automatic Tare: Automatic	When set to Automatic, the scale will automatically lock and hold the first stable weight reading on the display. When the weight is removed the scale will automatically clear the result. Once the result is cleared the scale will automatically tare and prepare for the next weighing.
Semi-Automatic	Display Hold initialization: Automatic Result Clearing: Manual Tare: Manual	When Set to Semi-Automatic, the scale will automatically lock and hold the first stable weight reading on the display. When the weight is removed it must be manually cleared. Before starting the next weighing the scale must be manually tared.
Manual	Display Hold initialization: Manual Result Clearing: Manual Tare: Manual	When set to manual, the first stable weight reading on the display must be locked manually. When the weight is removed it must be manually cleared. Before starting the next weighing the scale must be manually tared.

(E) Percent Weighing

1. To enable percent weighing, press the “T” (YES) key when *Percent* is displayed



- Commands *Pe On* and *Pe OFF* will be displayed sequentially. To enable percent weighing press the “T” (YES) key when *Pe On* is displayed. If the function is already enabled and you wish to disable it, press the “T” (Yes) key when *Pe OFF* is displayed.

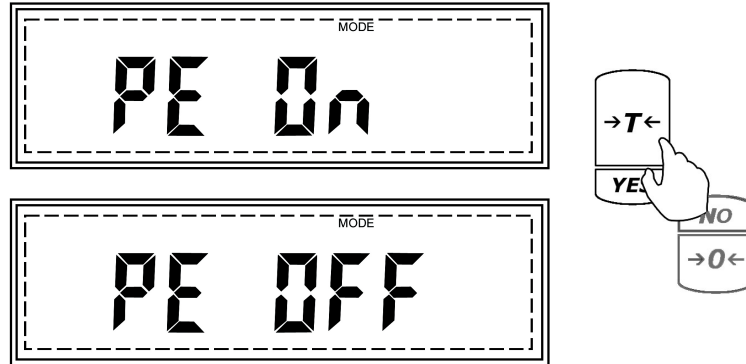

- After enabling percent weighing, *DONE* will be displayed, indicating that the function has been enabled and it is ready to use. To use the function, follow the directions in Chapter 8. To exit the mode menu use the “C” key.

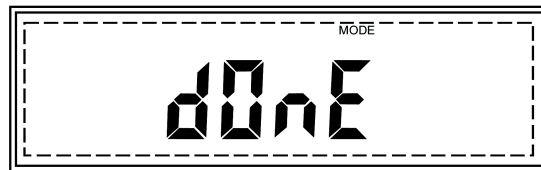

(F) Totalizing

- To enable totalizing press the “T” (YES) key when *Total* is displayed.

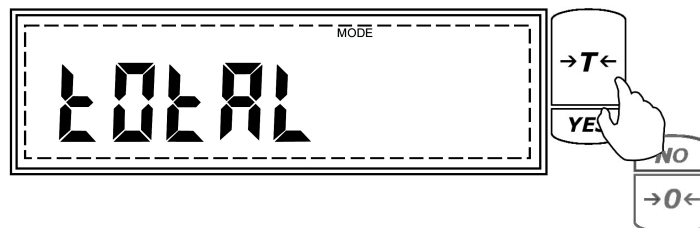

2. Commands *tot On* and *tot OFF* will be displayed sequentially. To enable totalizing and proceed with configuration press the “T” (YES) key when *tot On* is displayed. If the function is already enabled and you wish to disable it, press the “T” (Yes) key when *tot OFF* is displayed.

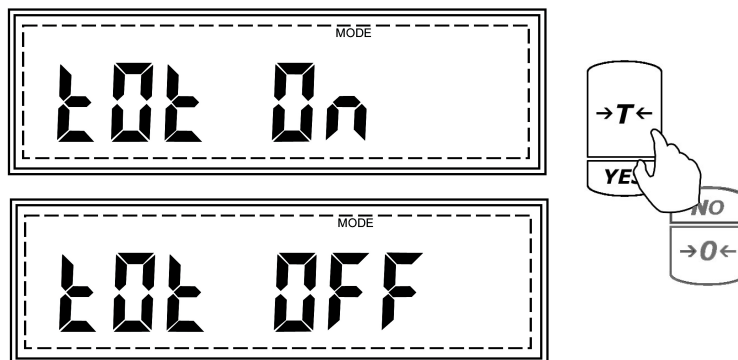

3. The totalizing function can operate in two different operating modes: automatic, and manual (see Table 7.1.3.F). The operating modes will scroll once the function is enabled. To select a desired operating mode for the totalizing function, press the “T” (YES) key while the mode is displayed. I.e. to enable automatic totalizing, press “T” (YES) when *AUTO* is displayed.



4. After enabling the totalizing function, *DONE* will be displayed, indicating that the function has been configured and it is ready to use. To use the function follow the directions in Chapter 8. To exit the mode menu, use the “C” key.





Table 7.1.3.F: Totalizing Operating Modes

Automatic	Totalizing and Adding: Automatic	When set to Automatic, the scale will automatically add the first stable weight reading to the total.
Manual	Totalizing and Adding: Manual	When set to Manual each weigh has to be manually added to the total by pressing a designated key.

7.1.4. Automatic Zero Setting Mechanism (AZSM)

All AGC scales are equipped with AZSM, the “Auto Zero Setting Mechanism.” AZSM automatically maintains a “center of zero” condition within +/- 6d (i.e. 6 mg on scales with 0.001 readability). To enable or disable AZSM follow the steps below.

1. Enter the Main Menu by pressing the “MENU” key.

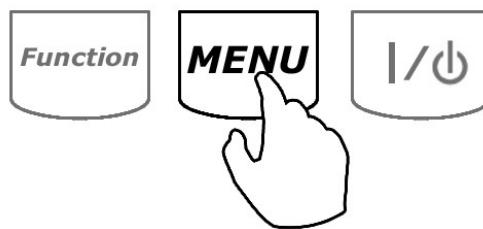

2. When command *AUTO* is displayed press the “T” (YES) key.



3. Command *AUT On* and *AUT OFF* will flash.

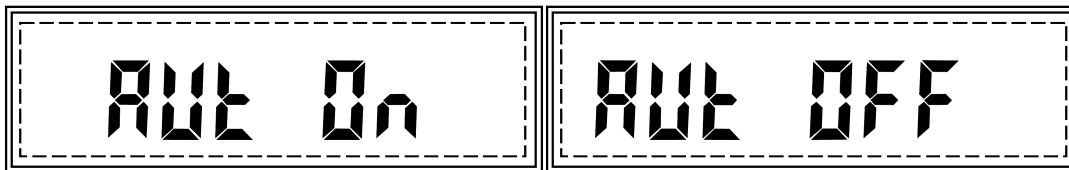

4. To enable AZSM press the “T” (YES) key when *AUT On* is displayed. To disable AZSM press the “T” (YES) key when *AUT OFF* is displayed.

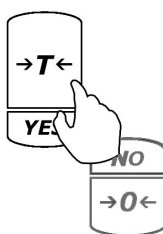

5. Once enabled, the *AUT* indicator will be displayed.

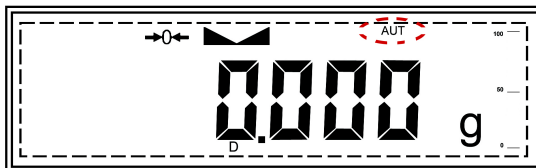



7.1.5.GLP Print and Data Configuration

When enabled, GLP data will appear on every printed transaction receipt. The GLP printout includes Model No., Unit ID, User ID, Project No., Notes / Remarks field, and a Signature field.

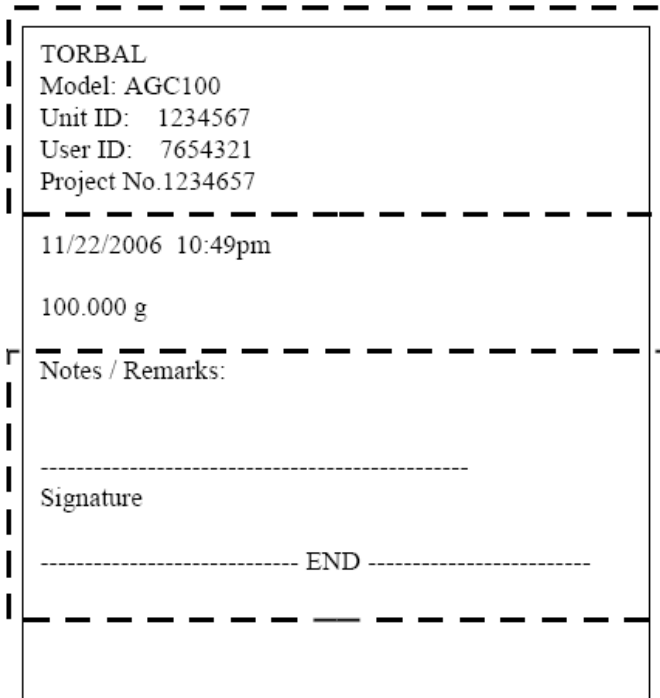

To enable and configure GLP data printing, follow the steps below:

1. Enter the Main Menu by pressing the “MENU” key.

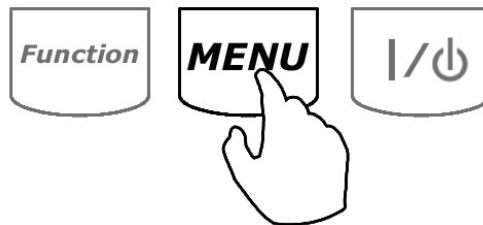

2. When command *GLP* is displayed press the “T” (YES) key.

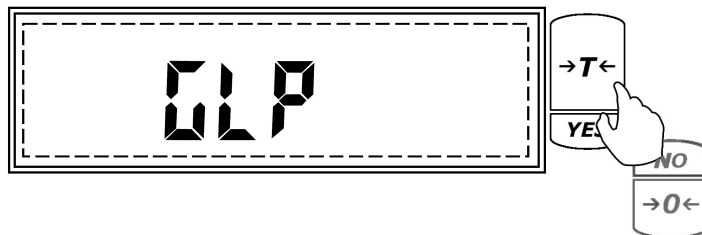

3. Commands *Set*, *Model*, *Unit ID*, *User ID*, and *Project ID* will begin to scroll.

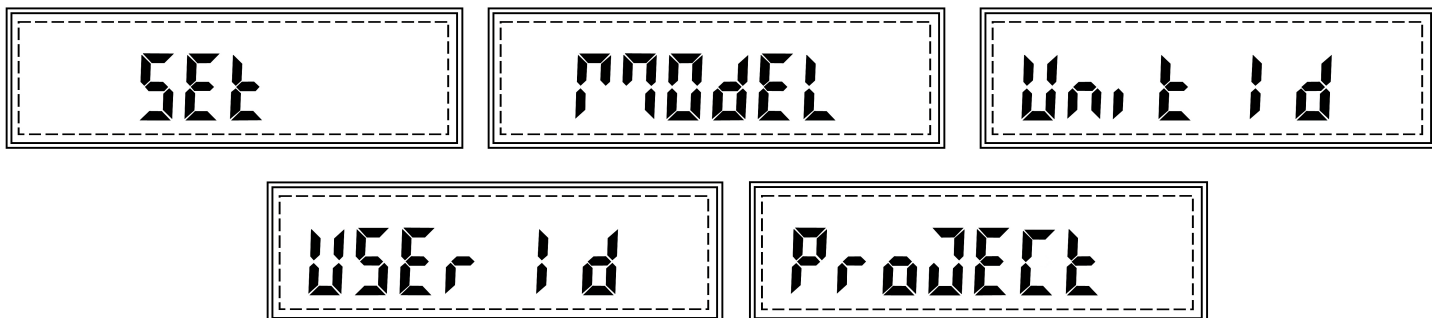

4. To enable or disable GLP press the “T” (YES) key when command *SET* is displayed.

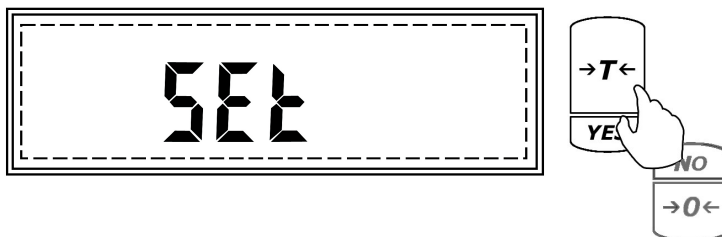

5. Commands *ON* and *OFF* will be displayed. To enable GLP press “T” (YES) when *ON* is displayed, to disable GLP press “T”(YES) when *OFF* is displayed.

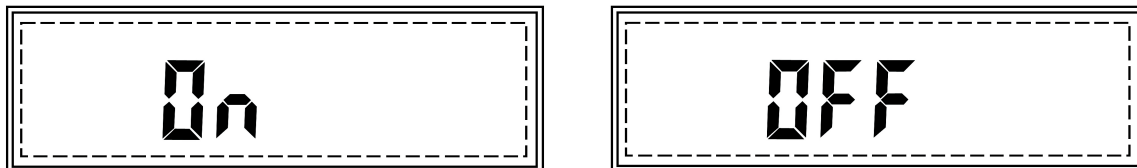

6. Once enabled, GLP options will begin to scroll on the display: *Model No.*, *Unit ID*, *User ID*, and *Project No.*

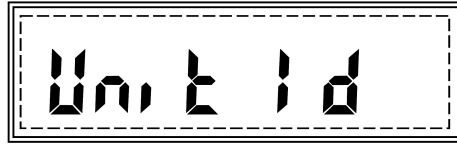

7. Press “T” (YES) when the desired option is displayed.

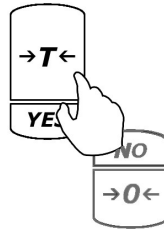

8. A minus sign will be displayed, indicating you may assign a new ID or project number.

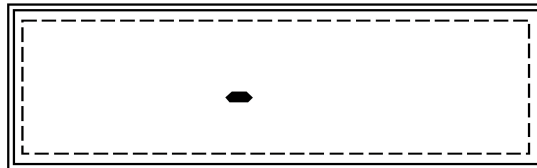

Note: ID numbers can consist of up to six digits long.

9. To enter an ID or a number, use the following keys: $\rightarrow 0 \leftarrow$ (NO) to increment a digit, “T” (YES) to accept and go to the next digit, “Function” to accept the entire setting, and “C” to clear and start over. To become familiar with entering an ID, refer to the example in Table 7.1.5.9.

To increment and change digits

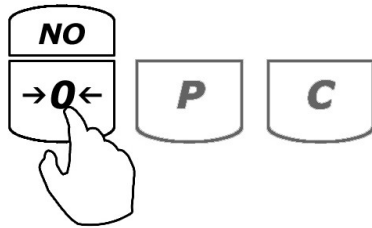

To accept and move to the next digit

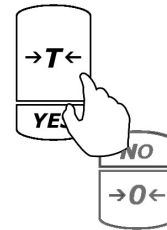

Table 7.1.5.9 Example: Setting an ID 54321

<i>Current Display</i>	<i>Action to take</i>	<i>Key to use</i>	<i>Number of depressions</i>	<i>Display becomes</i>
-	Increment the digit	$\rightarrow 0 \leftarrow$ (NO)	6	5
5	Accept and go to next digit	T (YES)	1	50
50	Increment the digit	$\rightarrow 0 \leftarrow$ (NO)	4	54
54	Accept and go to next digit	T (YES)	1	540
540	Increment the digit	$\rightarrow 0 \leftarrow$ (NO)	3	543
543	Accept and go to next digit	T (YES)	1	5430
5430	Increment the digit	$\rightarrow 0 \leftarrow$ (NO)	2	5432
5432	Accept and go to next digit	T (YES)	1	54320
54320	Increment the digit	$\rightarrow 0 \leftarrow$ (NO)	1	54321
54321	Accept the entire setting	Function	1	--

7.1.6. Printing Data and RS232 Communication Port Configurations

The printing function is used to print data via the RS232 port. Data may be printed via a printer or sent to a PC via the TORBAL Communication software.

7.1.6.1. Baud and Parity

To configure the scale's RS232 port for printing or to create a PC connection follow the steps below:

1. Enter the Main Menu by pressing the "MENU" key.

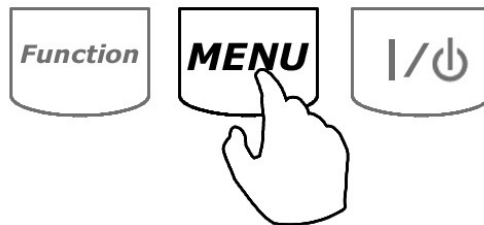

2. When *Print* is displayed press the "T" (YES) key.

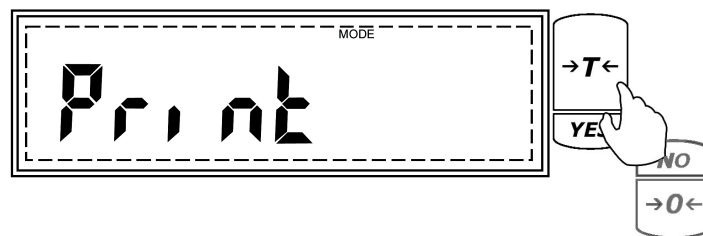

3. *Baud* and *Parity* will display.

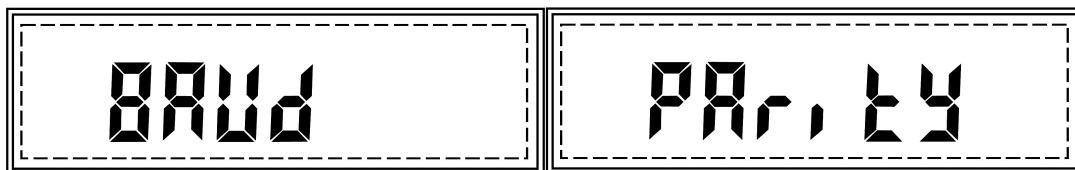

4. To configure the Baud rate settings press the “T” key when *Baud* is displayed. To configure the Parity setting press “T” key when *Parity* is displayed.

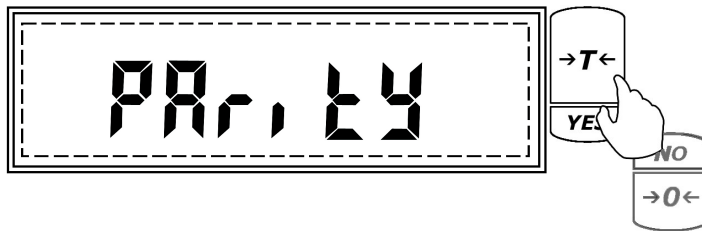
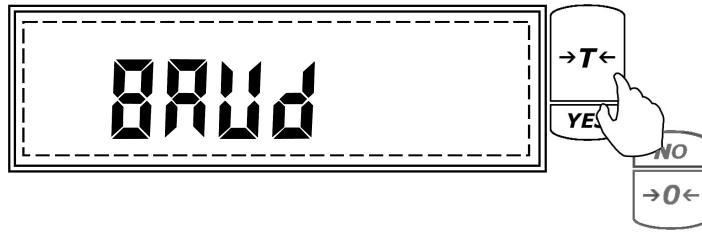

5. After pressing “T” when *Baud* is displayed, the scale will display available baud rates: 1200, 2400, 4800, and 9600. To make a selection press “T” (Yes) when the desired setting is displayed.

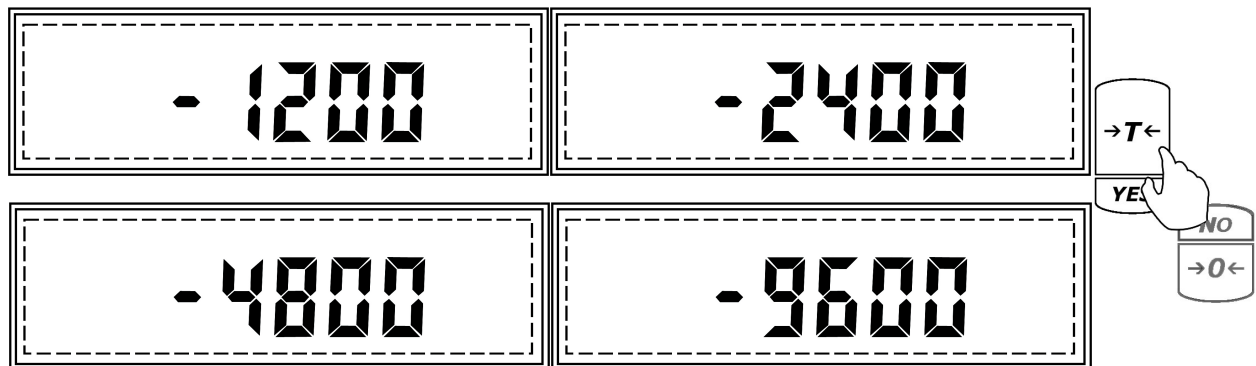



- After pressing “T” when *Parity* is displayed, the scale will display available parity settings: none, even, odd.

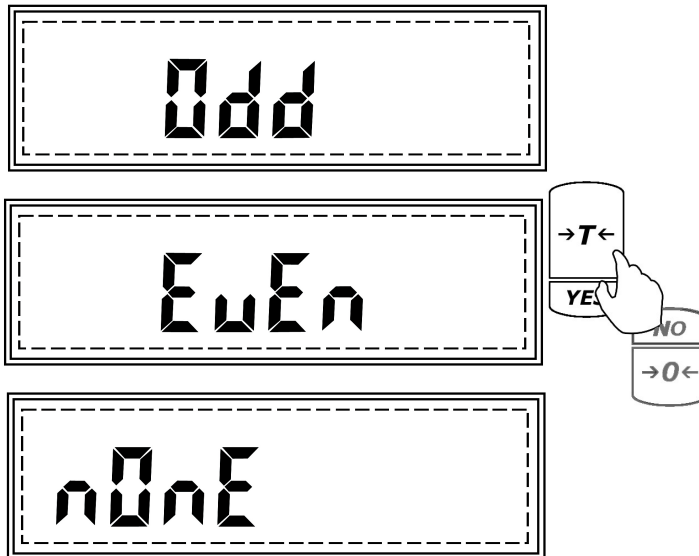

- To make a selection, press “T” (Yes) when the desired setting is displayed.

RS232 Port Configuration

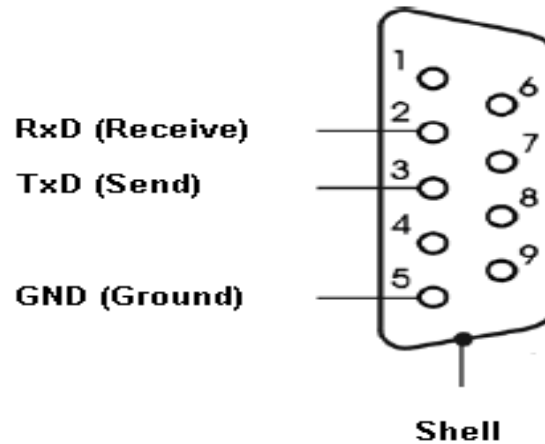

Note: When connecting the scale to a third-party software or third party printer, make sure that both the host (scale) and the slave are configured with the same Baud and Parity settings.

7.1.6.2. Torbald Printer Configuration (RXP-4)

To connect the AGC scale to a TORBAL (RXP-4) printer, use the following settings:

Scale settings (follow steps detailed in Section 9.1.1):

Baud Rate: 9600

Parity: None

Printer Settings (Follow the steps detailed in the RXP-4 Instruction Manual):

Baud Rate: 9600

Data: 8 bits

Parity: None / Ignore

Column Printing: 40

SW-1	SW-2	SW-3	SW-4	SW-5	SW-6	SW-7	SW-8
OFF	OFF	ON	ON	ON	OFF	OFF	OFF

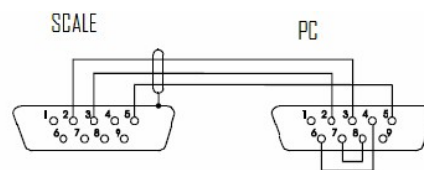
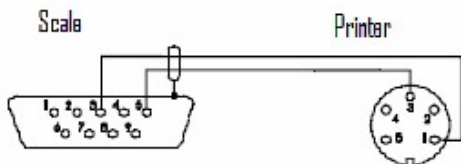



7.1.6.3. Printout Receipts

After completing a weighing transaction, result data receipt may be printed. To initiate printing, wait for the weighing result to stabilize and press the “P” key.

Note: Examples below include GLP data. For more on GLP printing, turn to Section 7.1.5

Check Weighing

```

TORBAL
Model: AD100
Unit ID: 1234567
User ID: 7654321
Project No.1234657

11/22/2006 10:49pm

Under Limit: 20.000g
Over Limit: 40.000g
Weight: 30.000g
Result: Accept

Notes / Remarks

-----
Signature

----- END -----
    
```

Parts Counting

```

TORBAL
Model: AD100
Unit ID: 1234567
User ID: 7654321
Project No.1234657

11/22/2006 10:49pm

Sample Size: 10
Average Piece weight: 0.500g

Piece Count: 30pcs

Notes / Remarks

-----
Signature

----- END -----
    
```

Percent Weighing

```

TORBAL
Model: AD100
Unit ID: 1234567
User ID: 7654321
Project No.1234657

11/22/2006 10:49pm

Reference Sample: 100g
Weight: 10g
Result: 10%

Notes / Remarks

-----
Signature

----- END -----
    
```

Totalizing

```

TORBAL
Model: AD100
Unit ID: 1234567
User ID: 7654321
Project No.1234657

11/22/2006 10:49pm

#1 20.000g_net
#2 10.000g_net
#3 5.000g_net

Total: 35.000g net

Notes / Remarks

-----
Signature

----- END -----
    
```

Display Hold and basic Weighing

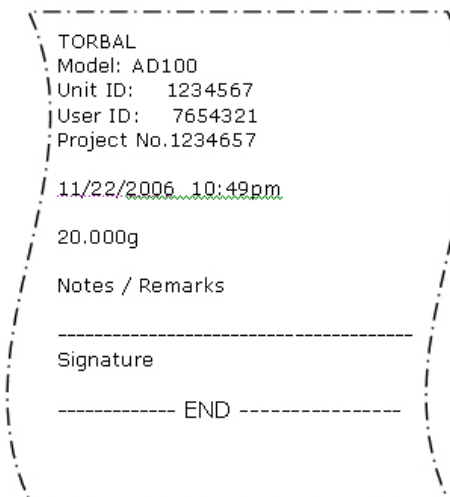

Animal Weighing

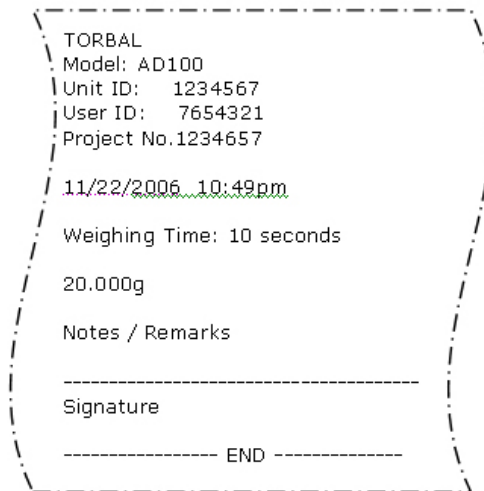

7.1.7. Time and Date

To set the current time and date, follow the steps below:

1. Enter the Main Menu by pressing the “MENU” key.

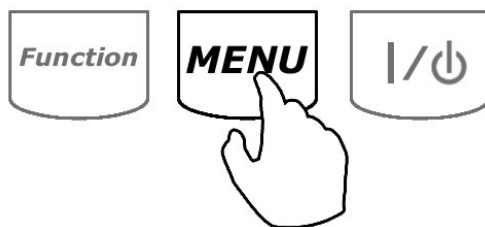

2. When *SET td* is displayed press the “T” (YES) key.

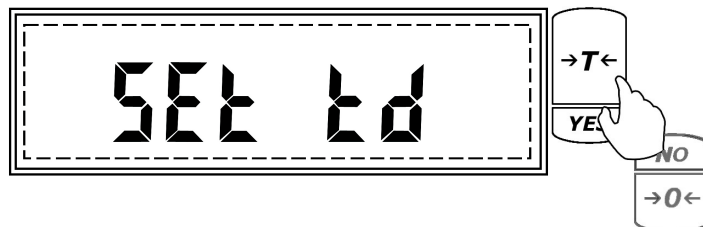

3. Commands *Time* and *Date* will flash.



Time:

1. To set the time press the “T” (YES) key when *Time* is displayed.

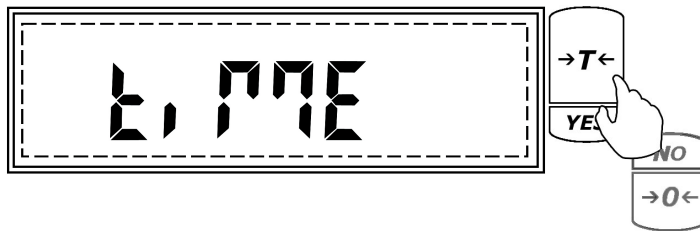

2. The current time setting will be displayed. To adjust the time press the →0← (NO) key.

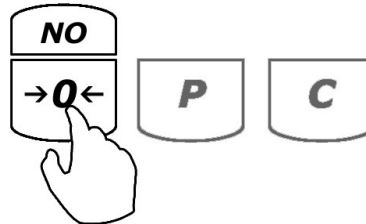

3. *A* and *P* will flash. To set AM press the “T” (YES) key when *A* is displayed, to set PM press the “T” (YES) key when *P* is displayed.
4. After making the selection, minutes will scroll. When the desired number is displayed, press the “T” (YES) key to accept and move to the next digit. Follow this sequence until the desired time is set. After setting the last digit of the hour, the time will be automatically saved.

Date:

1. To set the date press “T” (YES) when *Date* is displayed.



2. The current date setting will be displayed. To change the date, press “T” (YES).

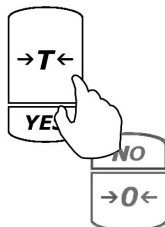

3. The year digit will scroll. Once the desired year is displayed press “T”(YES) to accept and move to the next digit. Follow this sequence until the desired date setting is displayed. After setting the last digit of the month, the date will be automatically saved.

7.1.8.Reset (restoring default factory settings)

The *Reset* function allows resetting all modes and applications as well as restoring default factory settings (see Table 7.1.5). To restore default factory settings follow the steps below.

1. Enter the Main Menu by pressing the “MENU” key.

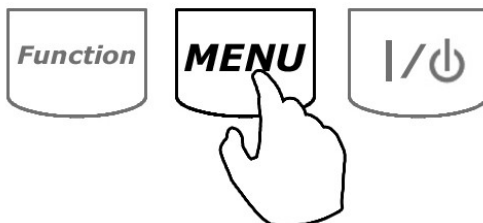

- When *RESET* is displayed press the “T” (YES) key.

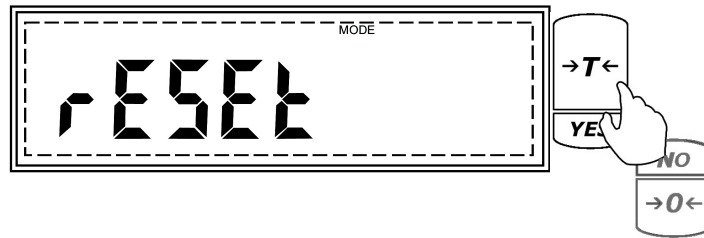

- The scale will display *YES – NO* in order to confirm reset initialization.



- To confirm and initialize the reset function, press the “T” (YES) key. To cancel and abort the reset press the →0← (NO) key.

To confirm Master Reset

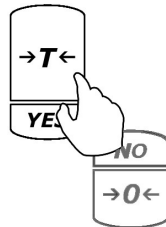

To abort Reset

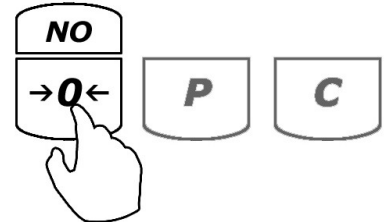

Warning: Resetting the scale will restore the default factory setting. Stored values will be lost and all functions will be disabled.



Weighing	Function: Always enabled
Animal Weighing	Function: Disabled Filtering time: t-3 (3 seconds)
Parts Counting	Function: Disabled Sample Size: 10 pieces
Check Weighing	Function: Disabled Under Value: 0.000g Over Value: 0.000g
Display Hold	Function: Disabled
Percent Weighing	Function: Disabled Percent Reference Sample: 0.000g
Totalizing	Function: Disabled

CHAPTER 8.**FUNCTION MENU: USING THE MODES AND FUNCTIONS**

All enabled and configured modes as well as applications are ready to use from the Function Menu. To select a function that was enabled and configured follow the steps below:

1. Press the “Function” key.

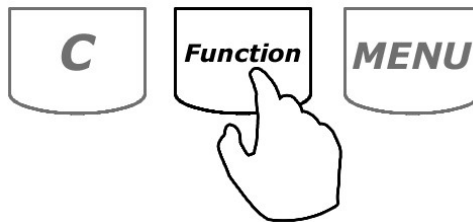

2. The enabled functions will scroll.

Note: Scrolling through the options may be accelerated by manually pressing the $\rightarrow 0 \leftarrow$ (NO) key.

3. When the desired function is displayed, press the “T” (YES) key. A letter corresponding to the selected function will appear on the lower portion of the LCD display, indicating that that the function has been activated.

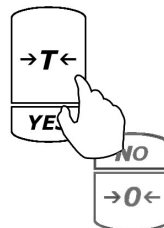

Note: To return to basic weighing, clear the current function by pressing the “C” key. Enter the Function Menu by pressing the “Function” key. When *WEIGH* is displayed, press the “T” (YES) key.

(A) Animal Weighing

1. Before weighing the animal, place an animal weighing container on the scale's pan and press "T" to tare the scale.



2. Once the scale has been tared, carefully place the animal in the container.



Automatic and Semi-Automatic:

When set to Automatic or Semi-Automatic, the scale will automatically begin the animal weighing process. Animal weighing will begin with the first weight reading.

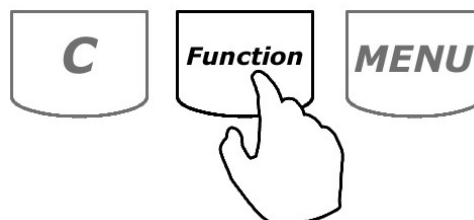

Note: In Automatic and Semi-Automatic modes the minimum weighing mass must be equal to or greater than 10d. To see this limit expressed in grams turn to detailed specifications on page 4.

Manual:

When set to manual, animal weighing must be initialized manually by pressing the “Function” key.

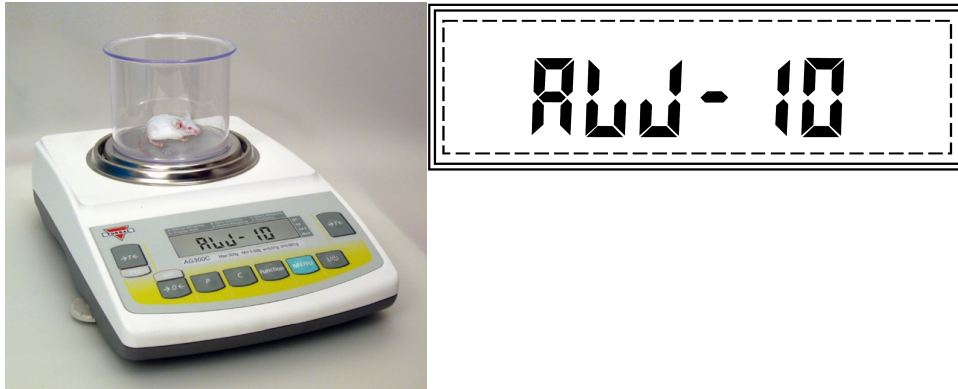

3. Once the animal weighing process is initialized, the scale will count down the time interval that was selected in the configuration mode. The countdown will display. During the time interval the scale will record weight readings of the animal and calculate its average weight.



4. After the time interval has elapsed the result will be displayed. The animal can now be removed from the pan.

Automatic:

When set to Automatic, the result will be automatically cleared after the animal is removed. The scale will perform an automatic tare and prepare for the next weighing. If the weighing container is changed the scale must be tared manually by pressing the “T” key.

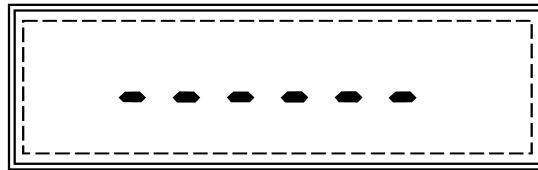

Semi-Automatic and Manual:

When set to Semi-Automatic or Manual, the weighing result will remain displayed and it must be manually cleared after the animal has been removed. To clear the weighing result, press the “C” key. After the result has been cleared, the scale must be tared. To tare the scale, press the “T” key.

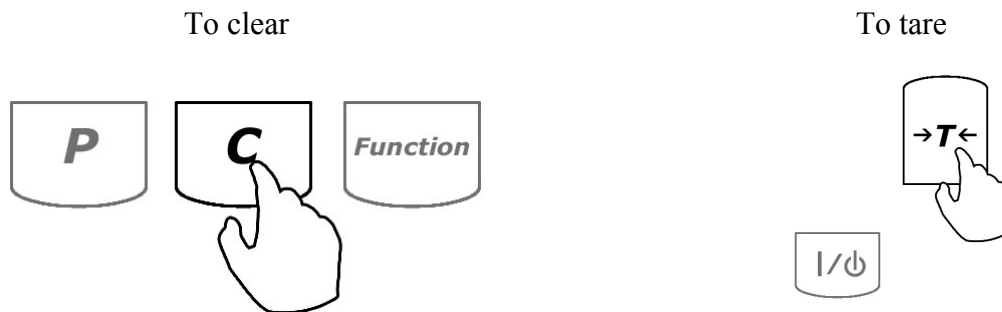

To exit animal weighing and switch to a different function, press “C” to clear the current function and then press “Function” to select a different function (follow Steps 1 through 3 from Chapter 8 on page 50).

(B) Parts Counting

1. Place an empty container on the pan and press the “T” key to tare.



2. After taring the container, the scale will display the sample size setting which was configured in the Mode Menu. For example *SPL-10* will be displayed, indicating that the current sample size setting is 10 pieces. To accept the sample size press the “T” (YES) key. To change the sample size use the →0← (NO) key.

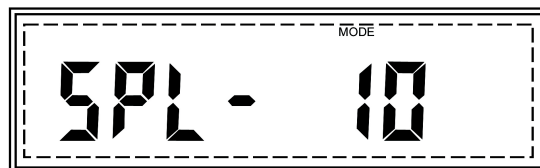

To Accept

To Change

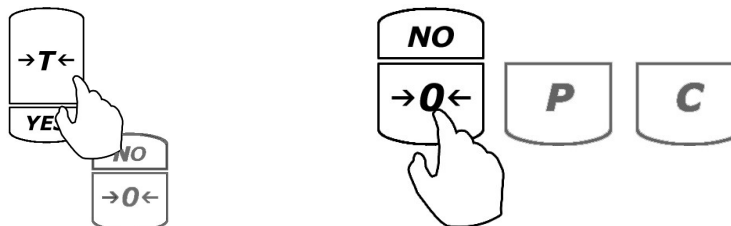

The sample size selection can range from 1 to 100 pieces. By applying short single presses to the →0← (NO) key the sample size will change in increments of one. By holding the →0← (NO) key pressed, the sample size will change in increments of 5. To select a sample size of 99, press and hold the →0← key until the display reads 95, and apply four single presses until the sample size reads 99. Once the desired sample size is displayed press the “T” (YES) key to accept and confirm the selection.

3. After confirming the sample size selection, the display will read *SAPL On*, indicating that you may now place the sample on the pan (10 pieces if SPL-10 is selected).



4. Manually count out the sample and place it in the counting container located on the pan.



5. The weight of the sample will be displayed as it is placed on the pan.

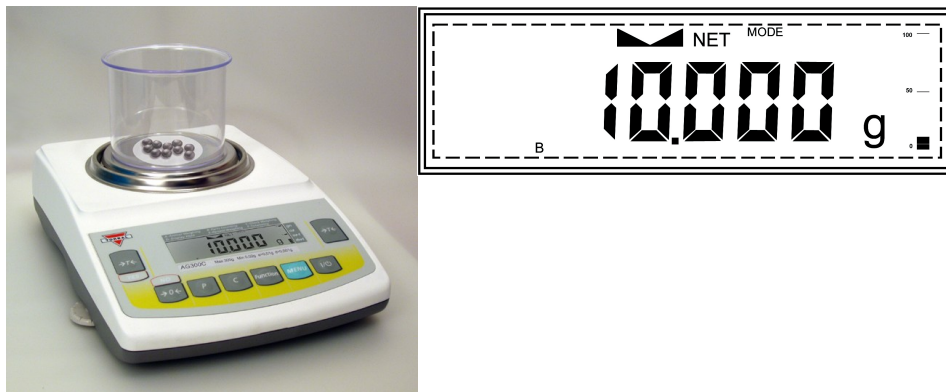

Note: Minimum individual piece weight must be equal to or greater than $3e$. Attempting to set an average individual piece weight which is lower than $3e$ will result in a Sample Low Error (SAPL LO). To see this limit expressed in grams turn to detailed specifications on page 4.

- Once the weight of the sample stabilizes and the stability indicator appears on the display, press “T” to confirm and accept the sample weight.

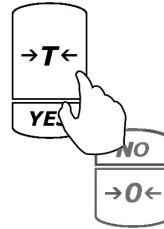

- The display will now indicate to begin filling. The word *FILL* will flash on the display for approximately 5 seconds. At any time during the *FILL* command, add the remaining pieces.



Note: If filling does not begin while the command *FILL* is displayed, after approximately 5 seconds the scale will display *10pcs* and will wait for the count to begin.

- The display will now indicate the number of pieces placed in the container. Stop filling when the desired count has been reached.

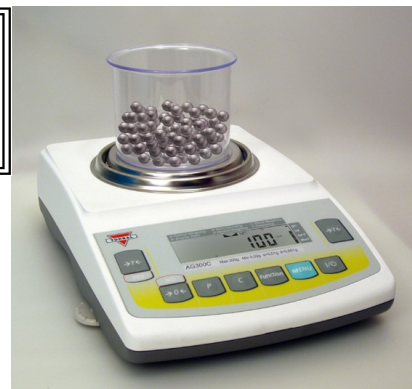
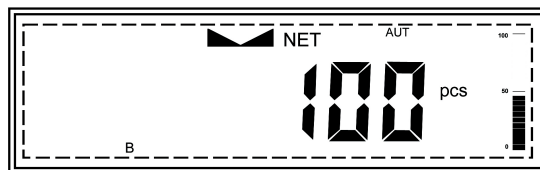

9. Once an accurate piece count has been taken, the container and its contents may be removed from the scale. After the container with the counted pieces has been removed, the scale will indicate the count is finished and that a new count may be initialized by pressing the “C” key. The command “ ---, *COUNT FINISH, TO START COUNT PRESS C* will appear on the display sequentially. To start a new count press the “C” key.

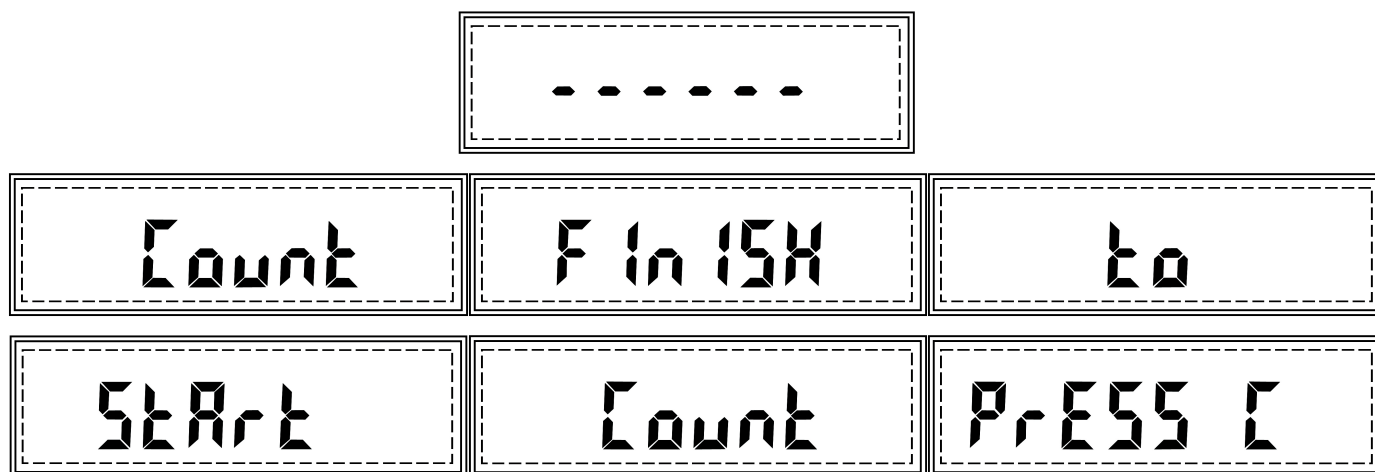

Note: If too many pieces have been placed into the container, remove the excess while the container is still on the scale’s pan. You may also remove the container from the pan, remove the extra pieces, and place it back on the pan to recheck the count. This may be performed while command “ ---, *COUNT FINISH, TO START COUNT PRESS C*” is displayed, but before pressing the “C” key. Once the “C” key is pressed the counting operation will reset.

To exit parts counting and switch to a different function, press “C” to clear the current function and then press “Function” to select a different function (follow Steps 1 through 3 from Chapter 8 on page 50).

(C) Check Weighing

The check weighing function is used to compare a weight of an object against a preset target range. To set the limits and use the check weighing function follow the steps below.

1. Upon entering the check weighing function, the *UNDER* limit is displayed. Command *UNDER* and the under-limit *weight setting* are displayed sequentially. If this is the first time the function is used, the setting will be 0.000g. Any new setting will be saved until changed or cleared through the master *RESET*.

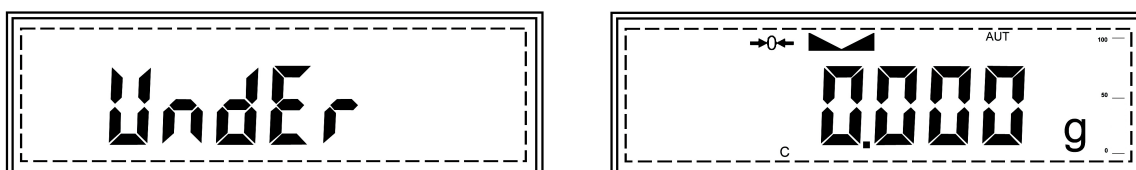

2. If an under limit has already been set and no change is necessary, press “T” (YES) to accept and continue. If you wish to change the setting, press the →0←(NO) key.

To accept

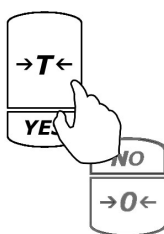

To change

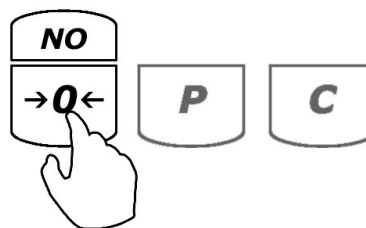

3. After pressing the →0← (NO) key a dash will appear on the display. A weight limit may then be entered.

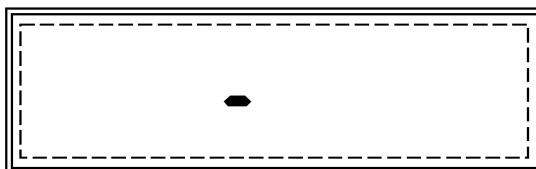

4. To enter a weight, use the following keys: the $\rightarrow 0 \leftarrow$ (NO) key to increment a digit; “T” (YES) to accept and go to the next digit; “P” to insert a decimal; “Function” to accept the entire setting; and “C” to clear and start over . To become familiar with setting the weigh limits, see Table 8.C.4.

Table 8.C.4, Example: Setting a weight limit of 20.123g

<i>Current Display</i>	<i>Action to take</i>	<i>Key to use</i>	<i>Number of depressions</i>	<i>Display becomes</i>
-	Increment the digit	$\rightarrow 0 \leftarrow$ (NO)	3	2
2	Accept and go to next digit	T (YES)	1	20
20	Insert a decimal	P	1	20.0
20.0	Increment the digit	$\rightarrow 0 \leftarrow$ (NO)	1	20.1
20.1	Accept and go to next digit	T (YES)	1	20.10
20.10	Increment the digit	$\rightarrow 0 \leftarrow$ (NO)	2	20.12
20.12	Accept and go to next digit	T (YES)	1	20.120
20.120	Increment the digit	$\rightarrow 0 \leftarrow$ (NO)	3	20.123
20.123	Accept the entire setting	Function	1	--

5. After setting the *UNDER* limit the current *OVER* limit setting will be displayed. Command *OVER* and the over-limit *weight setting* are displayed sequentially. If this is the first time the function is used the setting will be 0.000g. Any new setting will be saved until changed or cleared through the master *RESET*.



6. If an *OVER* limit is already set and no change is necessary, press “T” (YES) to accept and continue. If you wish to change the setting press $\rightarrow 0 \leftarrow$ (NO).

To accept

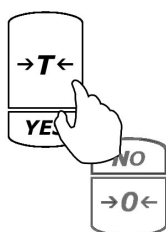

To change

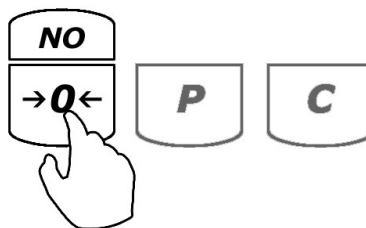

7. To change the *OVER* limit follow the directions in Step 4 of this section and Table 8.C.4.
8. Once both limits have been set the scale will display a *TARE* command, indicating that the scale must be tared. Before using the function place a container on the pan and press “T” to tare.

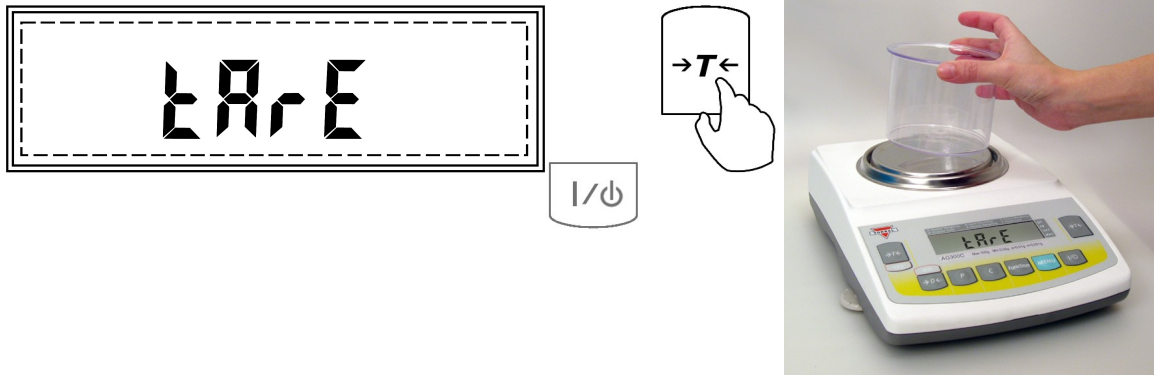

9. The scale is now ready to use. To perform check weighing place your object on the pan to check whether the weight of the object falls within the designated range. If the weight is less than the lower limit the scale will display the weight of the object and the command *UNDER*. If the weight falls within the range, the *ACCEPT* command will be displayed. If the weight exceeds the upper limit, the scale will display *OVER*.



Note: To change the limit setting press “C” and repeat Steps 1 to 7. If the same limits are used, the scale can be tared without clearing the function and the new object can be weight-checked. To exit check weighing and switch to a different function, press “C” to clear the current function and then press “Function” to select a different function (follow Steps 1 through 3 from Chapter 8 on page 44).

(D) Display Hold

The Display Hold function is used to retain a weighing result static on the LCD display after it has stabilized. To use the Display Hold function follow the steps below.

1. Place an empty container on the pan and press “T” to tare.



2. After taring the container, place the weight on the pan.

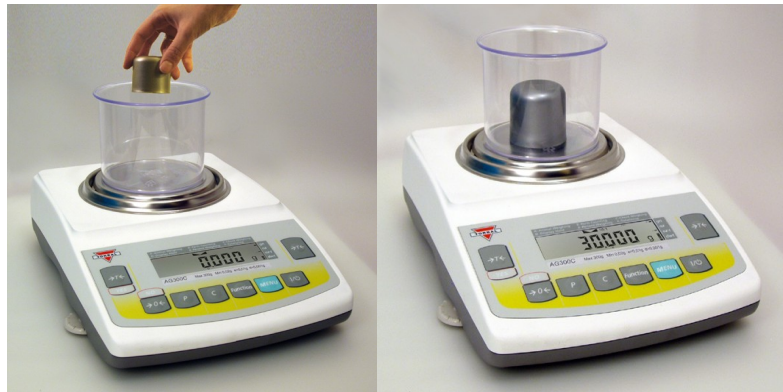



3. Weighing

Automatic and Semi-Automatic:

When set to Auto and Semi-Auto after weight has been added to the pan, the scale will automatically lock the weighing result on the display as soon as it stabilizes.

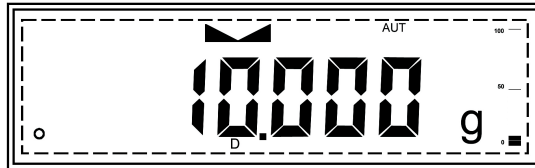

Note: In Automatic and Semi-Automatic modes the minimum weighing mass must be equal to or greater than 10d. To see this limit expressed in grams turn to detailed specifications on page 4.

Manual:

When set to Manual, display hold is initialized by pressing the “Function” key. Once the weight is stable press “Function” to lock the result on the display.

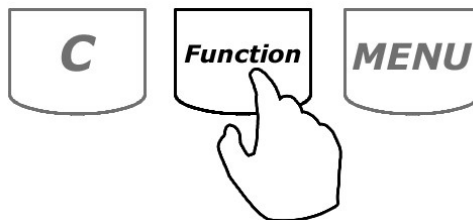

4. Clearing the display

Automatic:

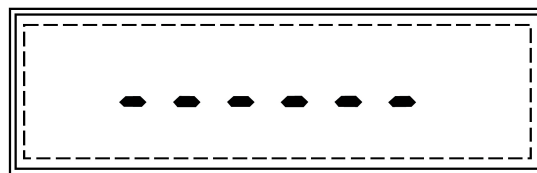

When set to Automatic, the result will be automatically cleared after the weight is removed from the pan. The scale will perform an automatic tare and prepare for the next weighing. If the weighing container is changed the scale must be tared manually by pressing the “T” key.

Semi-Automatic and Manual:

When set to Semi-Automatic or Manual, the weighing result will remain displayed and it must be manually cleared after the weight is removed from the pan. To clear the weighing result press the “C” key. After the result has been cleared the scale must be tared. To tare the scale press the “T” key.

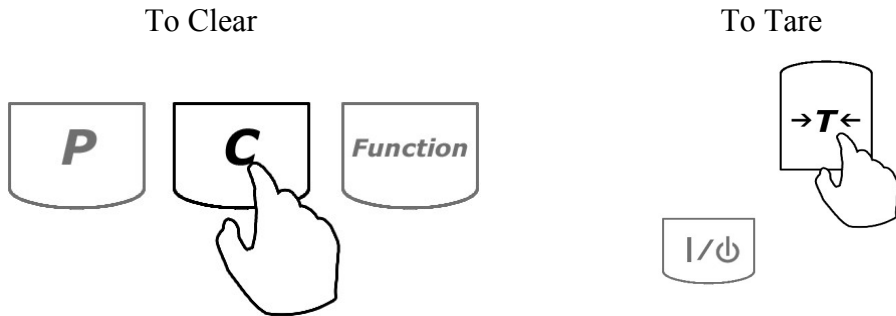

To exit Display Hold and switch to a different function, press “C” to clear the current function and then press “Function” to select a different function (follow Steps 1 through 3 from Chapter 8 on page 50).

(E) Percent Weighing

Percent weighing is used to express a weight of an object as a percentage of a stored sample weight. To use percent weighing follow the steps below.

1. Place a container on the pan.



2. Press “T” to tare the scale.

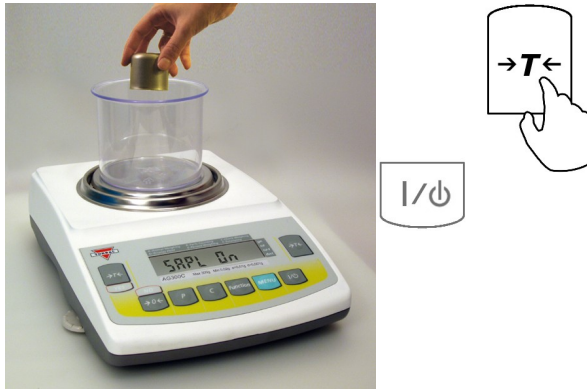

3. Once the scale has been tared, the scale will display the weight of a previously stored sample. If this is the first time the function is used, the sample weight will be 0.000g. To accept the current sample setting, press the “T” (YES) key. To assign a new sample, press the →0←(NO) key.

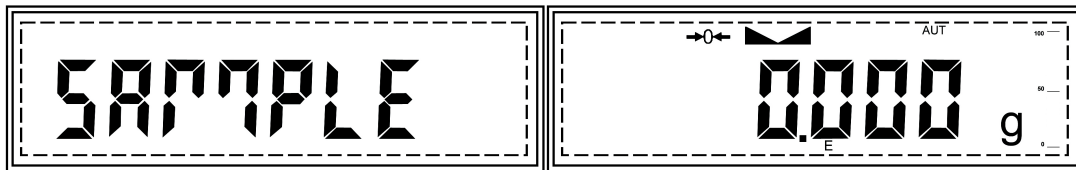

To accept

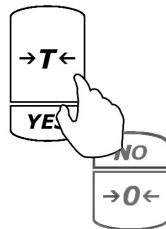

To change

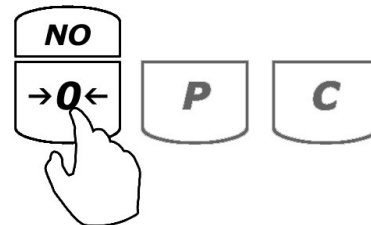

4. After pressing the →0← (NO) key command *SAPL ON* will be displayed.



5. Place the sample on the pan. The weight of the sample will be displayed.



Note: The reference sample must be equal to or greater than 100d. Attempting to set a sample lower than 100d will result in a *SAPL LO* error.

6. Once the weight of the sample has stabilized and the stability indicator has been displayed, press “T” to accept the sample. Once a new sample weight is set it will be saved until changed or cleared through the master *RESET*.

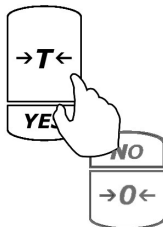

- After setting the sample weight, the command *READY* will be displayed. Remove the sample and place the object on the pan. The scale will express the weight of the object as a percentage of the stored sample.

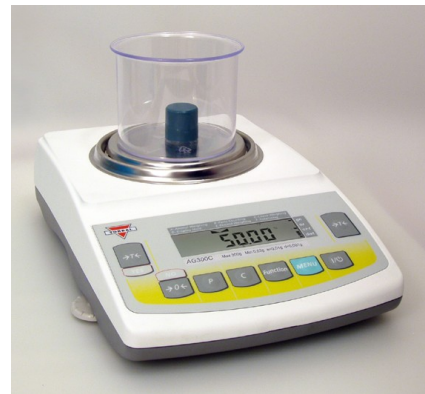
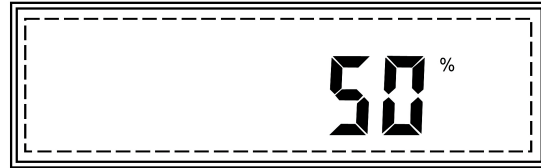

Note: To change the percent sample press “C” and repeat Steps 1 to 5. If the same sample weight is used, the scale can be tared without clearing the function and new objects can be weighed.

To exit percent weighing and switch to a different function, press “C” to clear the current function and then press “Function” to select a different function (follow Steps 1 through 3 from Chapter 8 on page 50).

(F) Totalizing

Totalizing is used to add and total weighing results. To use this function, follow the steps below.

1. Place a container on the pan and press “T” to tare.

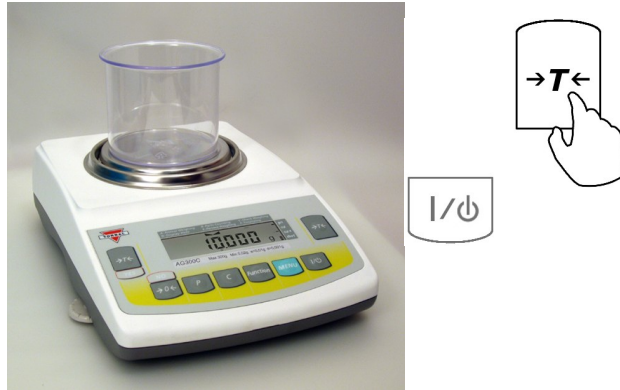

2. After taking a tare, place the first object on the pan.



Automatic

When set to Automatic, the weight of the object will be added automatically. Once the weight stabilizes, the *TOTAL* indicator will appear on the display, signaling that the weight has been added to the grand total.



Note: In Automatic and Semi-Automatic modes the minimum weighing mass must be equal to or greater than 10d. To see this limit expressed in grams turn to detailed specifications on page 4.

Manual

When set to Manual, the weight of the object must be added manually. Once the weight stabilizes and the stability indicator appears on the display press the “Function” key to add the weight to the grand total. Upon pressing “Function,” *TOTAL* will appear on the display, signaling the weight has been added to the grand total.

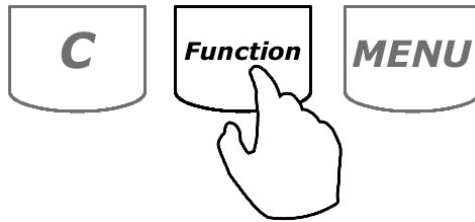

Note: With each added weight, the grand total result appears on the display for approximately three seconds. To recall the grand total at any time, press the “MENU” key.

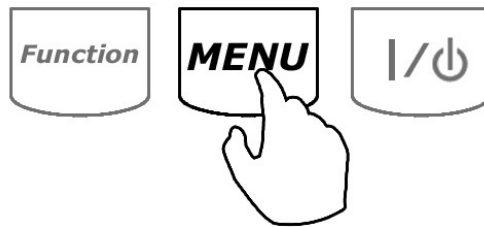

3. Once a weight of an object has been added to the total, remove the object from the pan or press “T” to tare the scale.

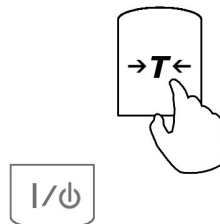

- After the scale has been tared, Steps 1 through 3 can be repeated to add more weighing results to the grand total.

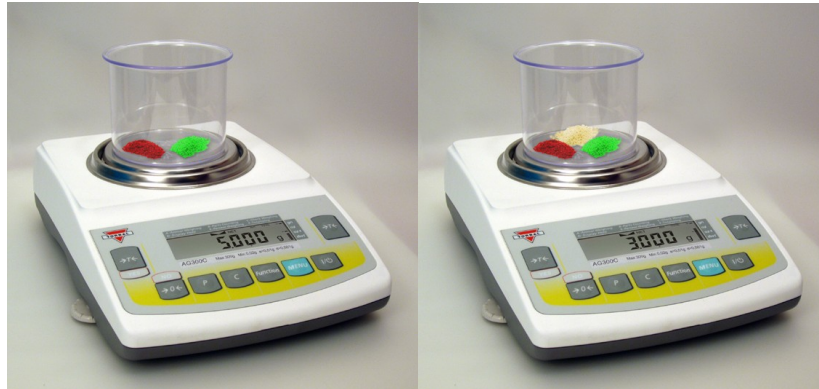

- To clear the grand total and reset the function press the “C” key.

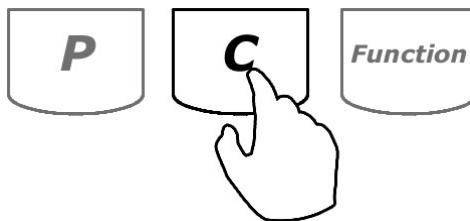

- Once “C” has been pressed, the command *YES-NO* will be displayed, asking to confirm clearing of the function. To abort the clearing the function press the $\rightarrow 0 \leftarrow$ (NO) key. To clear the function press the “T” (YES) key (all data will be lost).

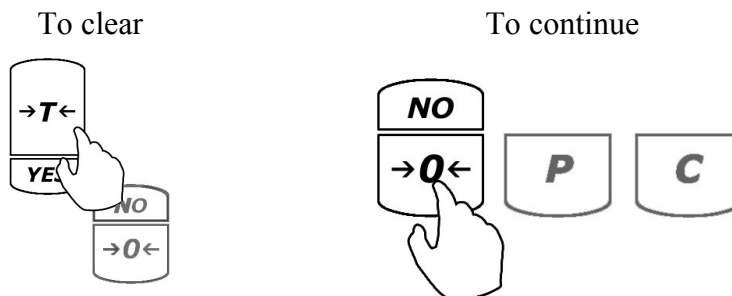

To exit totalizing and switch to a different function, press “C” to clear the current function and then press the “Function” key to select a different function (follow Steps 1 through 3 from Chapter 8 on page 50).

CHAPTER 9. TECHNICAL INFORMATION

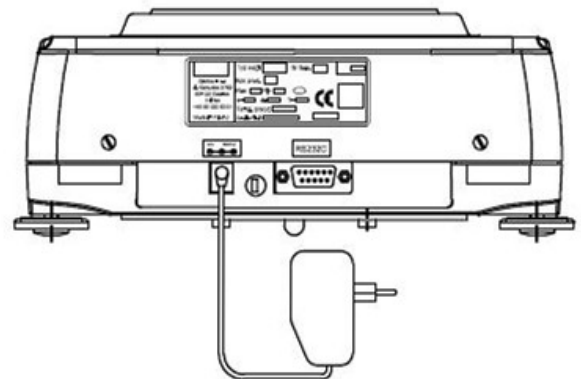
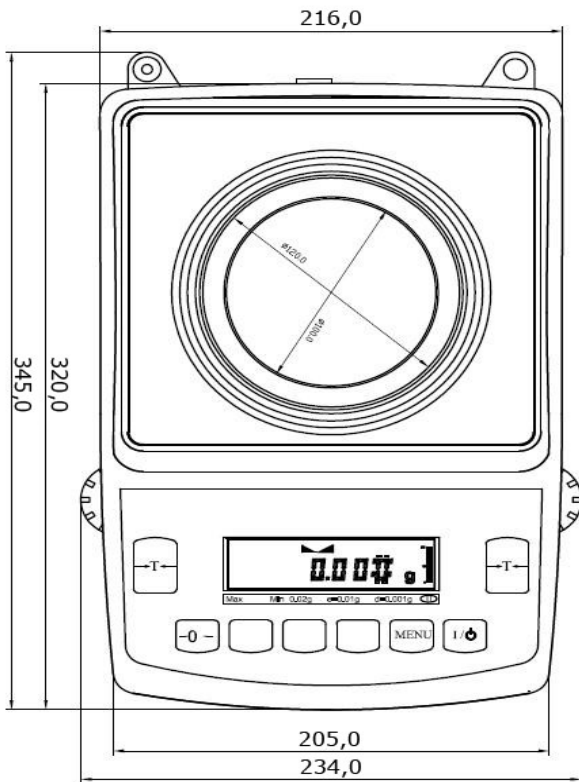
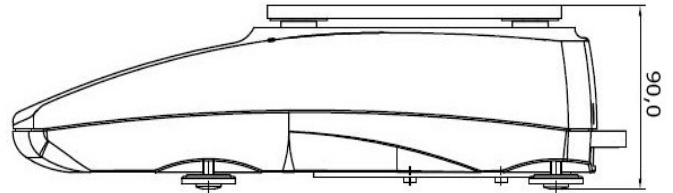
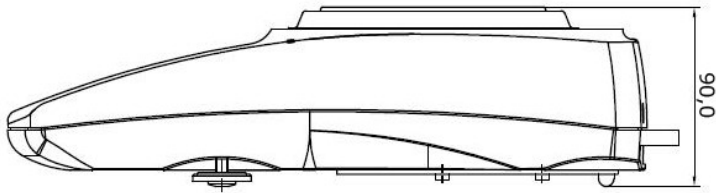



CHAPTER 10.

COMMON ERRORS AND TROUBLESHOOTING

Error or Indicator	Cause	Explanation / Solution
----	Below zero	Re-zero the scale by pressing the → 0← key.
--	Taring is not allowed	Place a weight on the pan before taking a tare.
- -	Re-zeroing is not allowed	Remove weight from pan and clear stored tare values
L	Pan error	Make sure that pan is properly seated on the pan support
.H	Exceeded capacity	The scale has exceeded its weighing capacity. Reduce the weight.
Err – b	Pan not cleared on power-up	The pan was not empty while the scale was initiating at startup. Clear the pan and restart the scale.
<i>Sapl LO</i> (Parts Counting)	Average piece weight is too low	The average piece weight is lower than 3e. Be sure that individual piece weight is greater than 3e.
<i>Sapl LO</i> (Percent Weighing)	Sample Reference weight is too low	The sample reference weight is lower than 100d. Increase the sample weight.
The scale will not turn on	Possible power failure	Check the power AC adapter connection
Weighing results are not accurate	Inaccurate calibration	Calibrate the scale
Weighing result will not stabilize	Irregular environment	Eliminate drafts or vibrations



CHAPTER 11. MAINTENANCE

Cleaning and maintaining your AGC Precision Scale:

- Before cleaning the scale always unplug the A/C adapter from the electrical outlet.
- Use a soft, slightly damp cloth to clean the exterior housing of your scale,.
- Wipe the scale gently. Do not allow any liquid to enter into the scale.
- Do not apply extensive pressure to the LCD display.
- Do not use chemicals or benzene when cleaning the surface. Corrosive chemicals may damage the finish.
- Alcohol may be used only to clean the scale's stainless steel pan or the draft ring.

CHAPTER 12. ACCESSORIES

Description	Part No.
Draft Shield Cover	AGC9120
RXP-4 Thermal Printer	AGC9130
RS232 PC Cable	AGC9140



CHAPTER 13.

REPLACEMENT PARTS

Description	Part No.
A/C Adapter	AGC9150
Pan Assembly	AGC9160
RS232 Printer Cable	AGC9170

CHAPTER 14.

LIMITED WARRANTY

PURCHASER'S 24-MONTH WARRANTY

Warranty is valid only if the attached warranty registration card is completed and returned within 30 days.

This product is a precision device made to exacting standards of scientific accuracy. It is guaranteed to have been adjusted and inspected for proper workmanship and performance, and certified for its currently advertised specifications before shipment.

Fulcrum Products are warranted against defects in material and workmanship under normal use and service. This warranty is extended only to the first purchaser. This limited warranty will not apply if, upon inspection, it is found that the product was tampered with, misused, overloaded, or abused. mishandled, placed in an improper environment, improperly installed or adjusted, used for a purpose other than that for which it was designed, or repaired by unauthorized personnel.

Fulcrum's liability under this warranty is limited to furnishing labor and parts necessary to remedy the defect covered by this warranty and restore the product to normal operating condition. Purchasers may be charged a minimum repair fee for in-warranty products returned for repair if those products are determined to be problem-free. To make a claim under this limited warranty, obtain an RMA number from Fulcrum and return the product, carefully packed in its original packaging, shipping prepaid, with the RMA number written on the return package.