

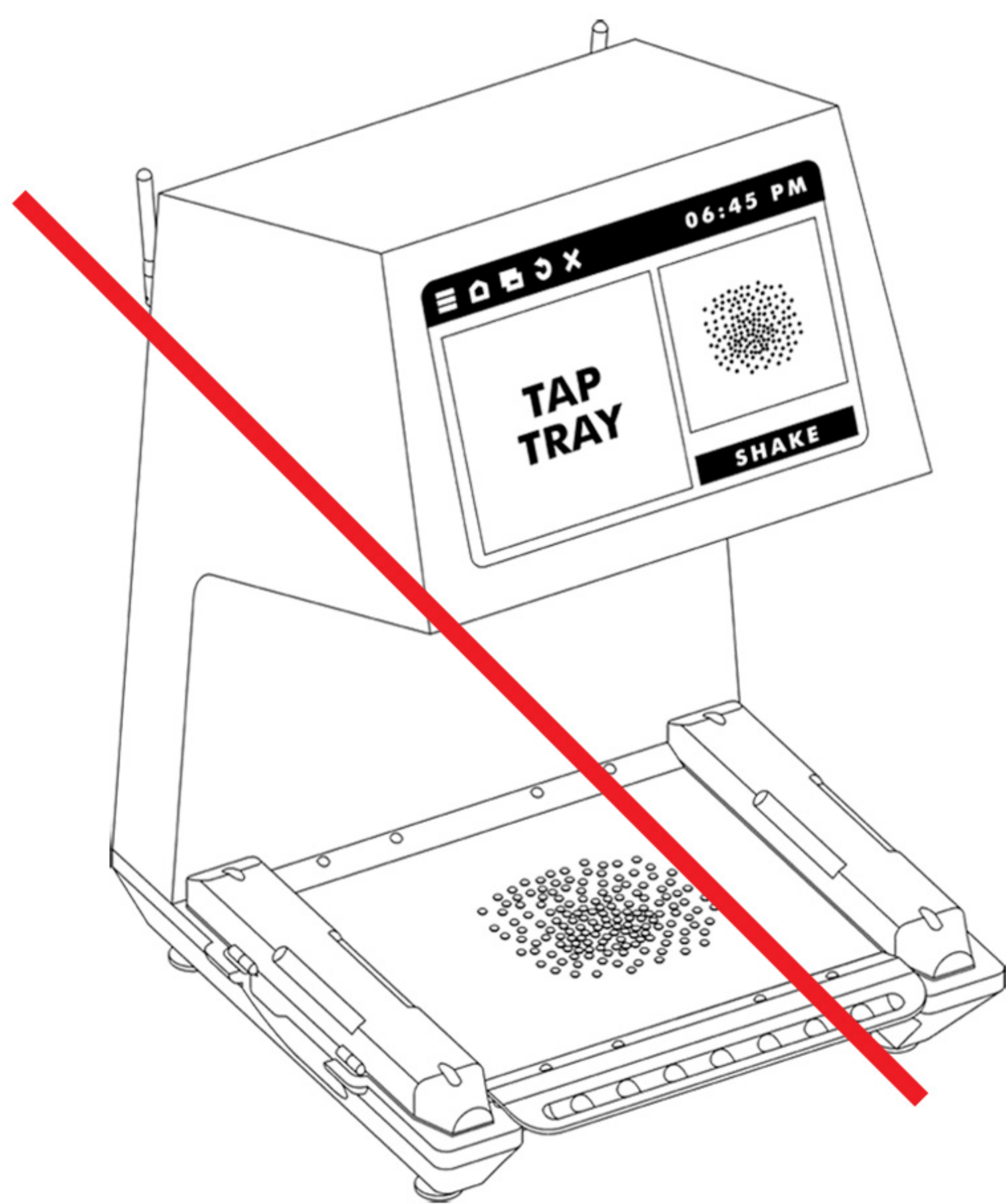

Tips and Good Habits While Counting

After dispensing pills onto the tray, always tap the tray to assure pills spread away from each other.

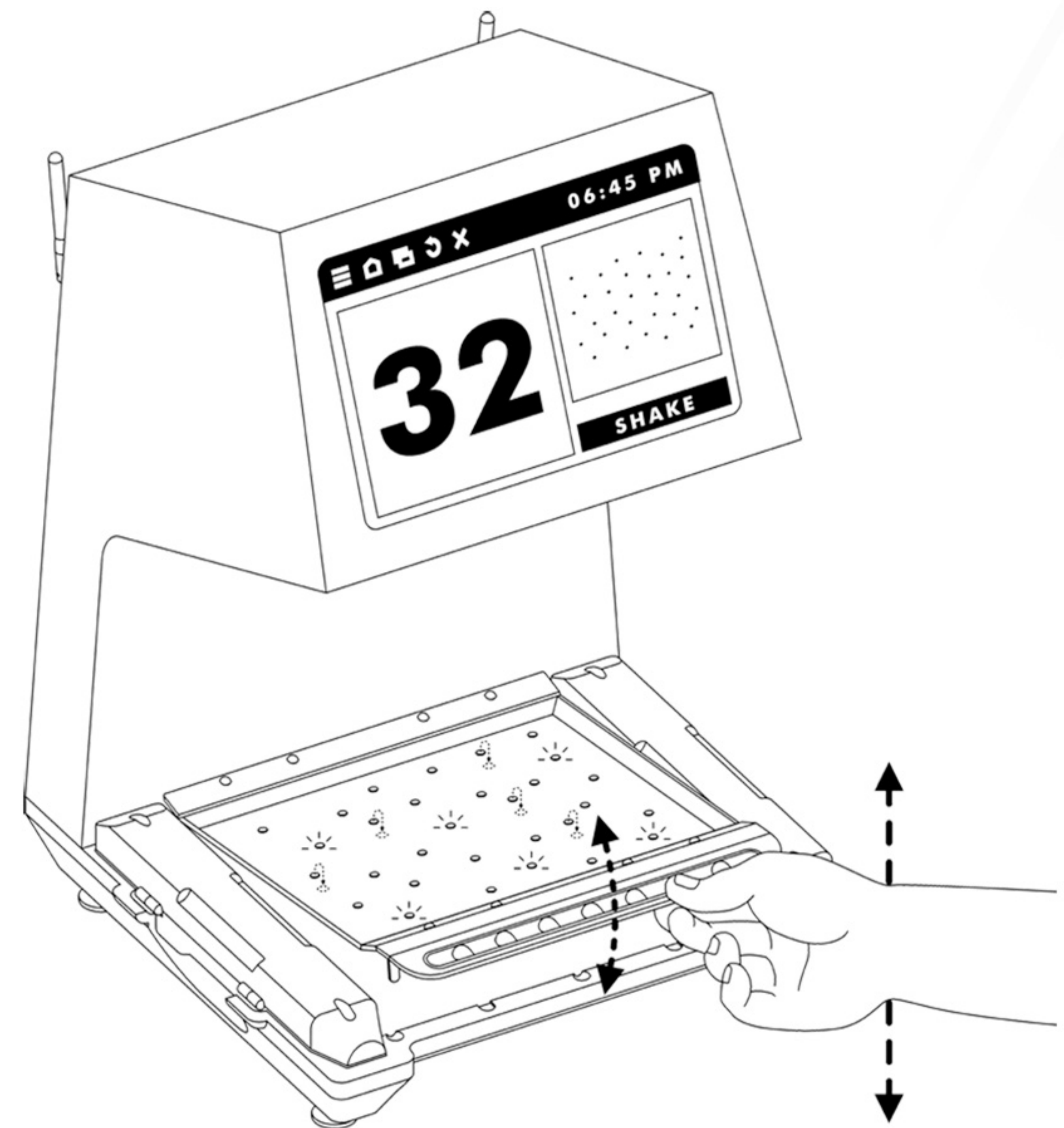

Do not dispense the pills into a single heap or tight cluster.

Avoid exceeding a quantity of 100 pills in a single count. Use batching for large quantities.

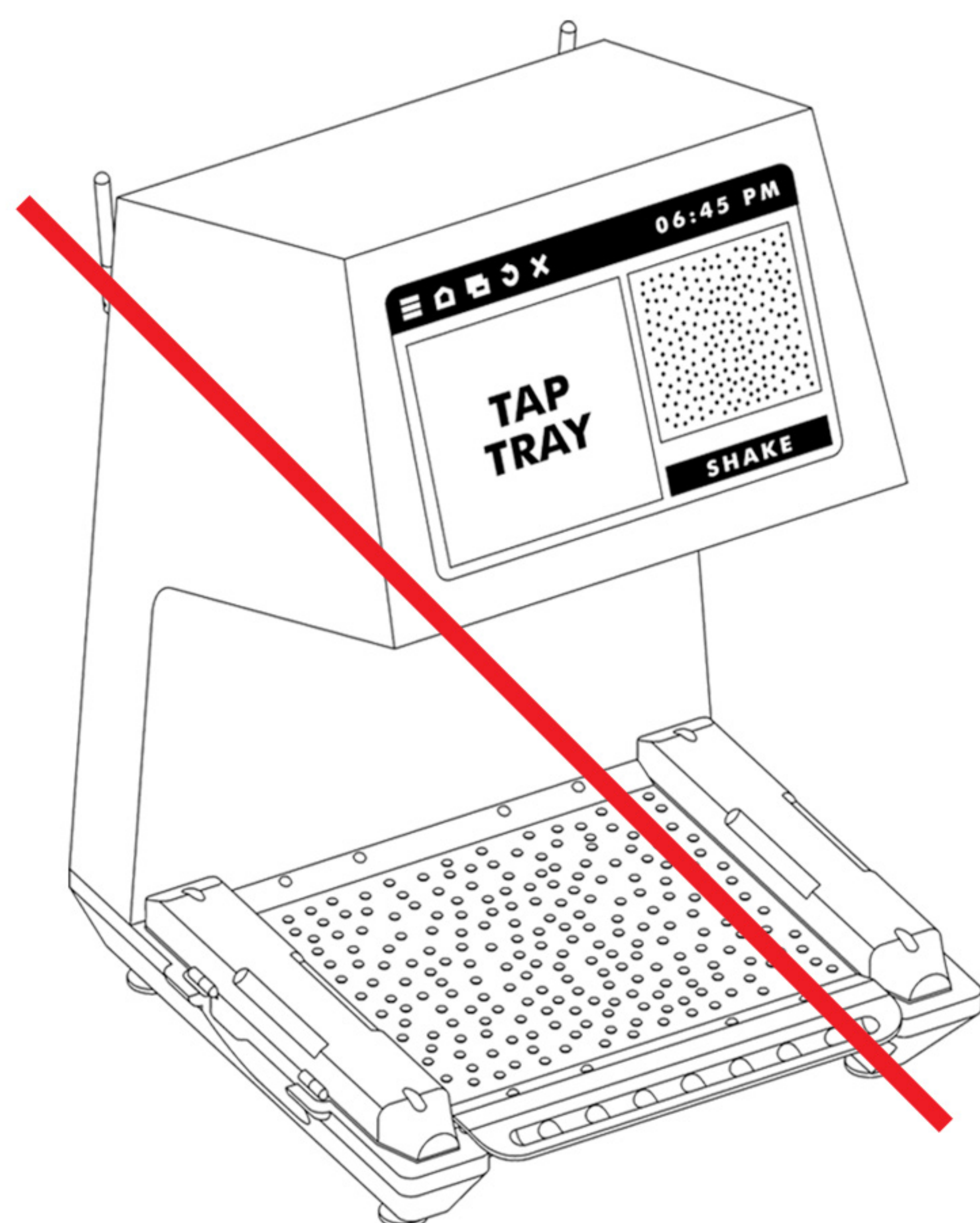



Glance at the surface of the tray and verify that pills are not stacked one on top of another.

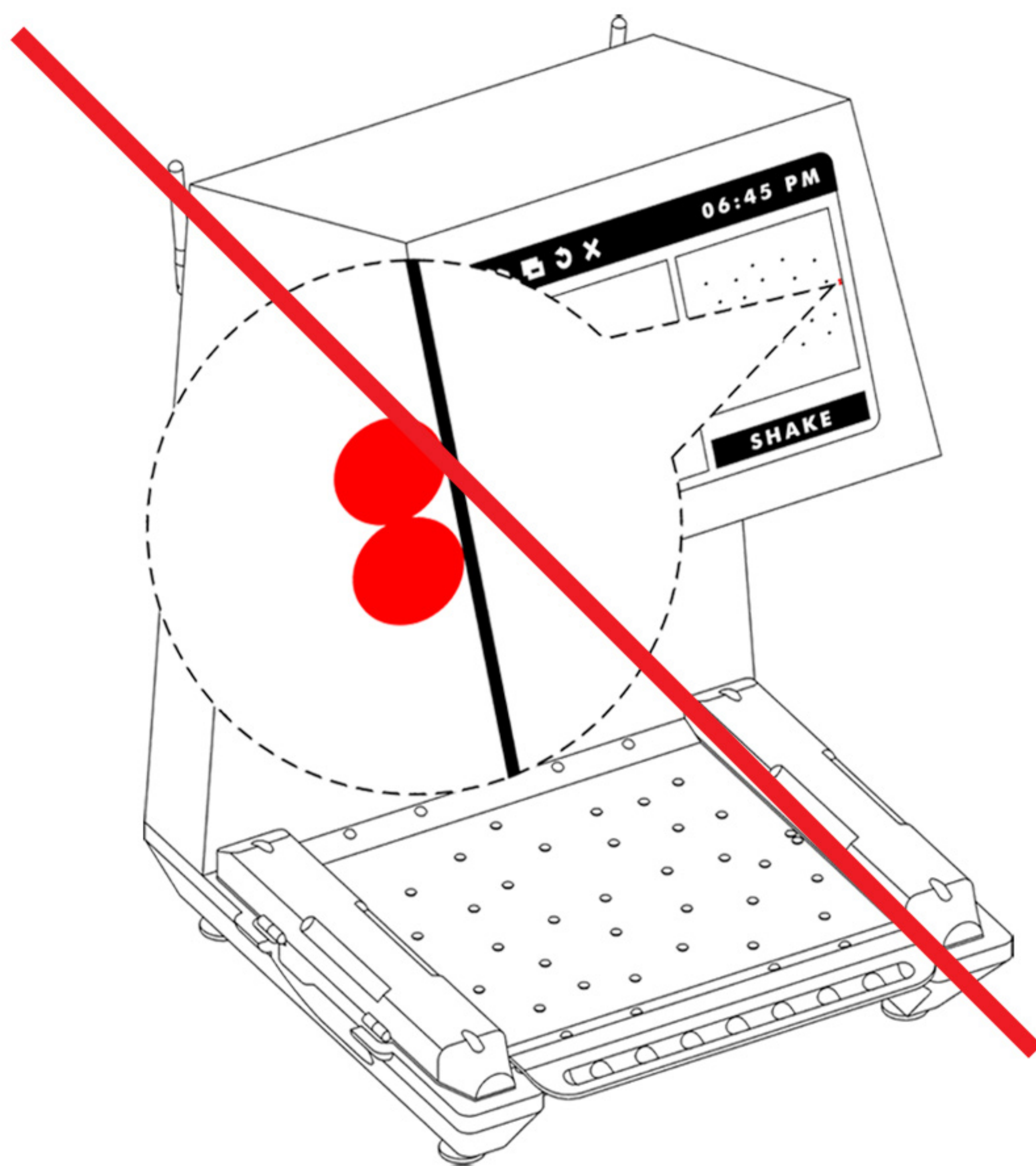
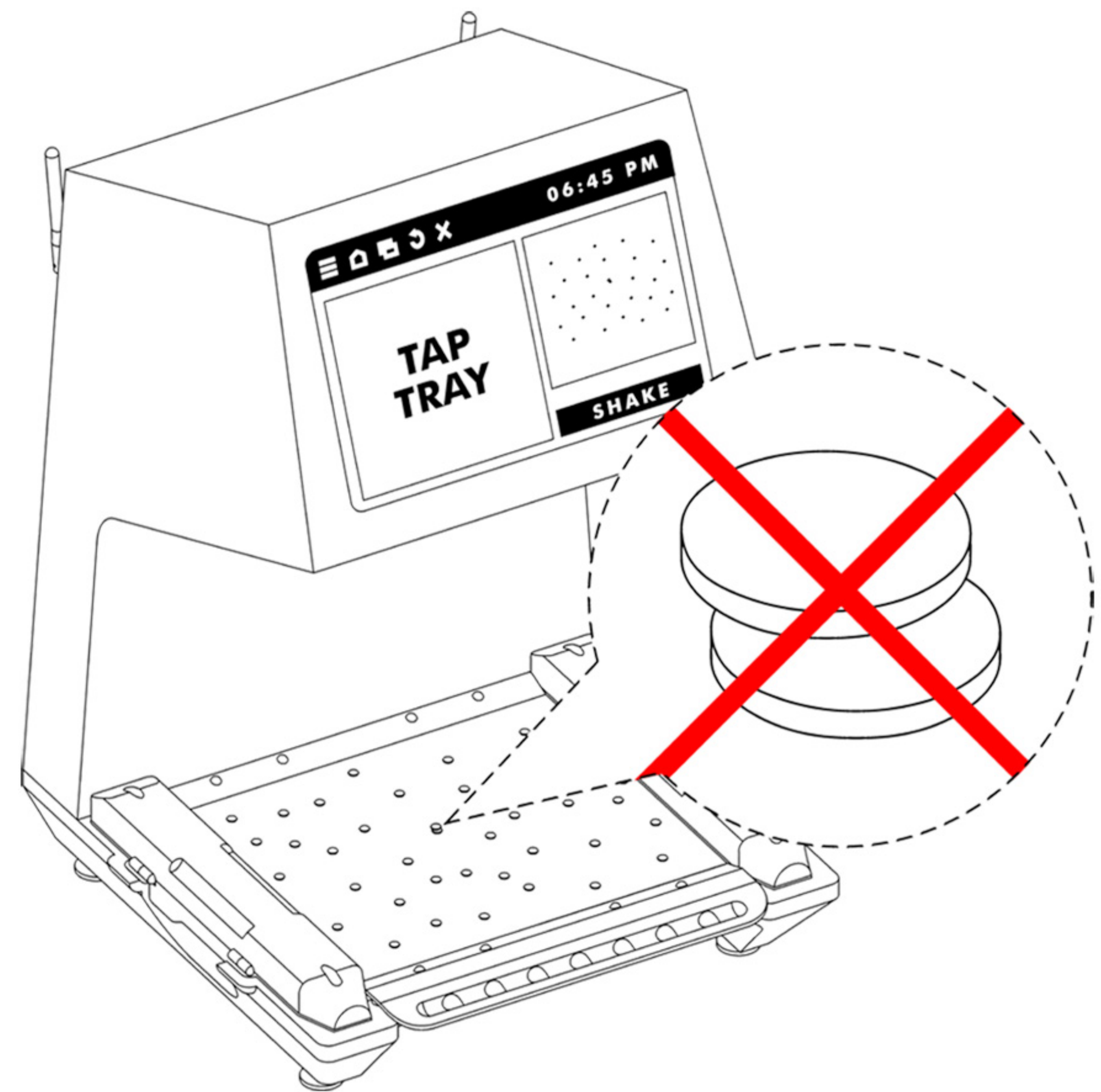

Be sure that none of the pills on the image display are marked red. Pills marked in red are too close to the edge of the tray and are not counted. Tap or shake the tray until the pills move away from the edges of the tray.

Glance at the image of the pills and make sure each pill is marked green. Pills without a green mark are not counted. Make sure multiple pills are not marked with one mark, or a single pill is not marked with multiple markers. Flashing green may represent a cluster. If you see any of the above tap or shake the tray.

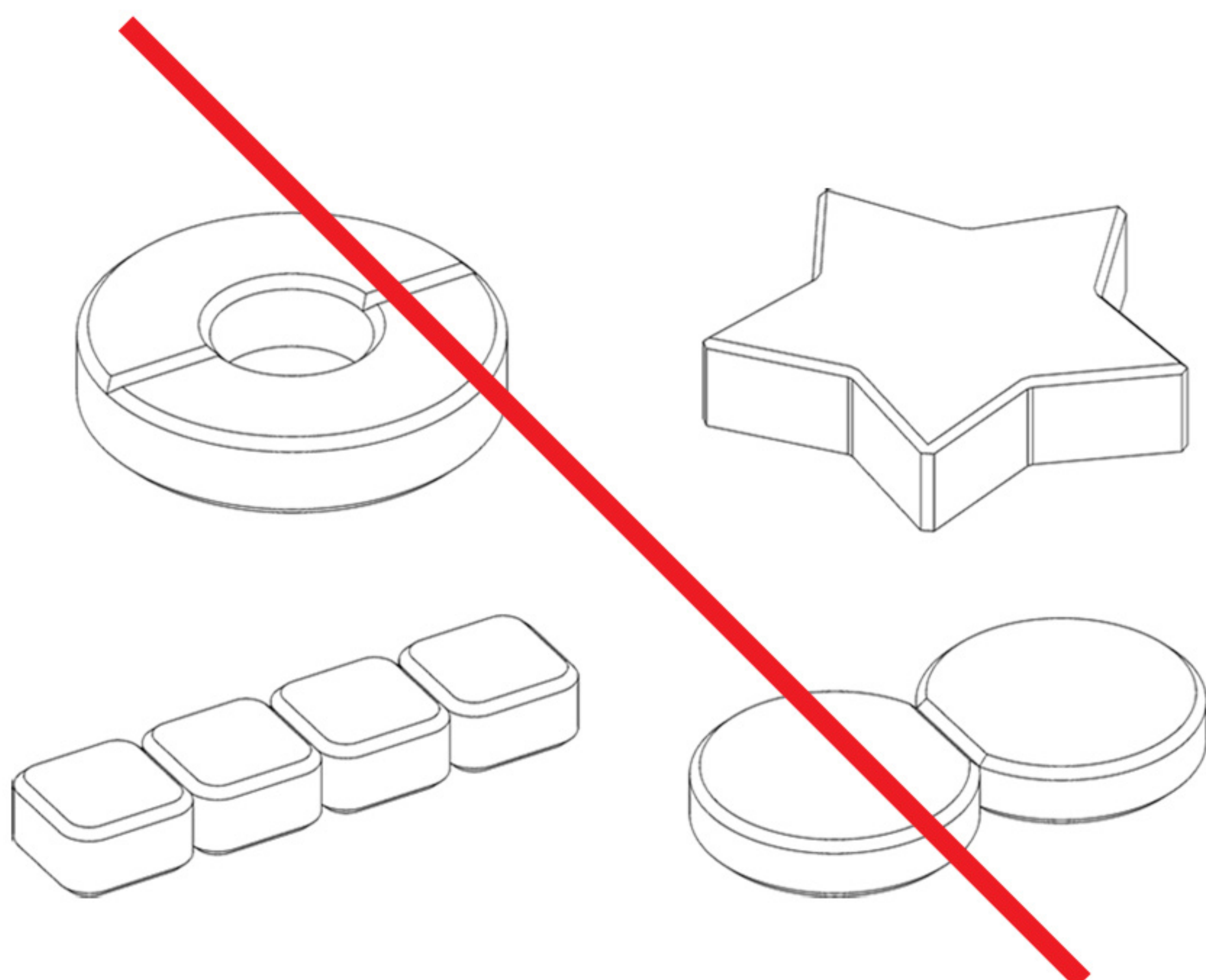
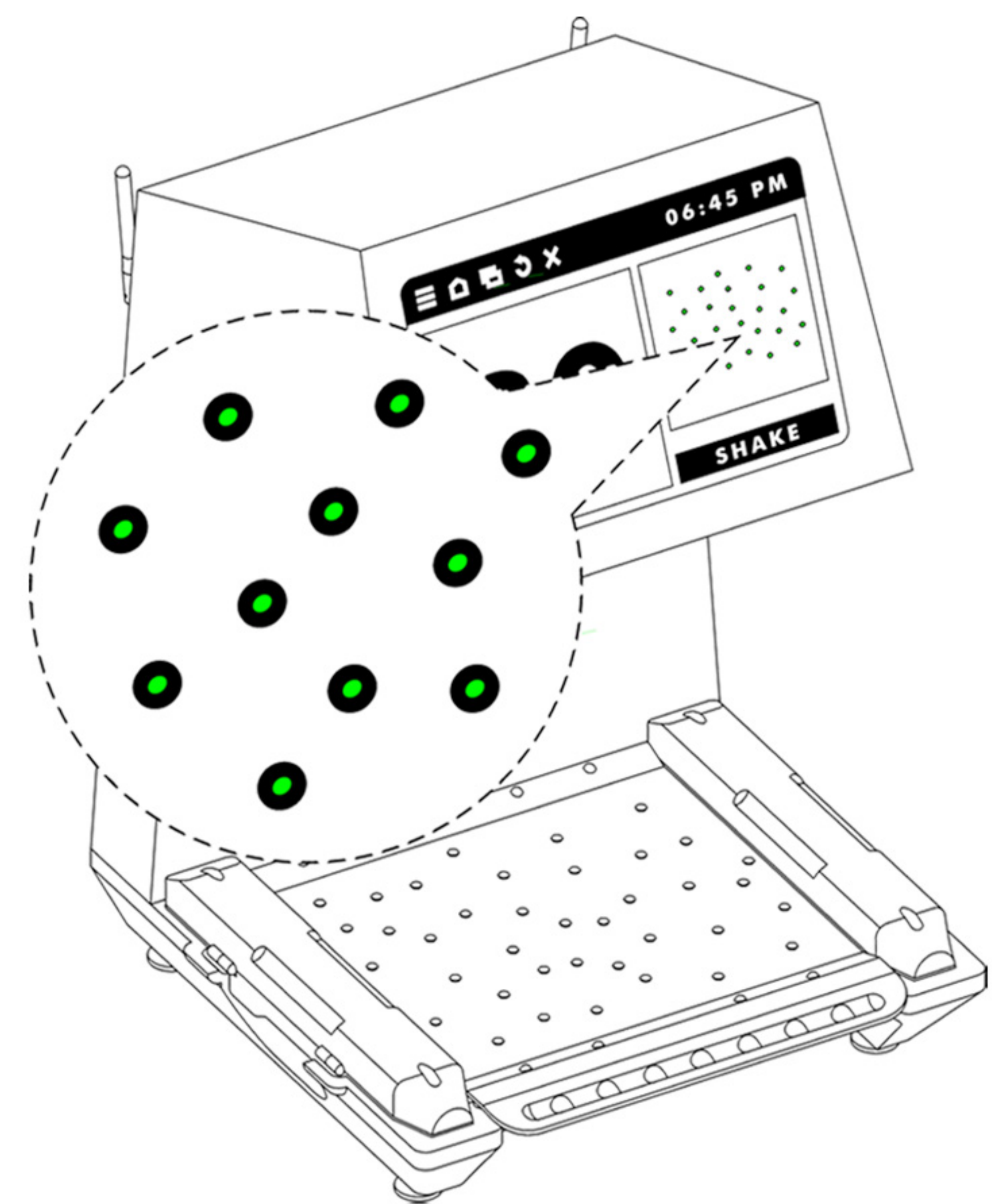

The VIVID cannot detect translucent pills. Do not count pills with a thru-hole and avoid counting pills with obscure shapes. Always check to make sure a single pill is not marked with multiple green markers.